

# AMA SERIES



## MAGNETICALLY DRIVEN CHEMICAL PUMP

# USER MANUAL

AMA-DT/FP

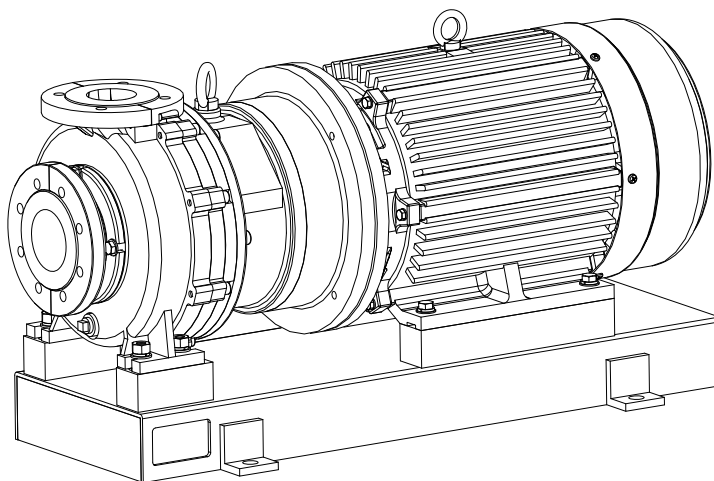

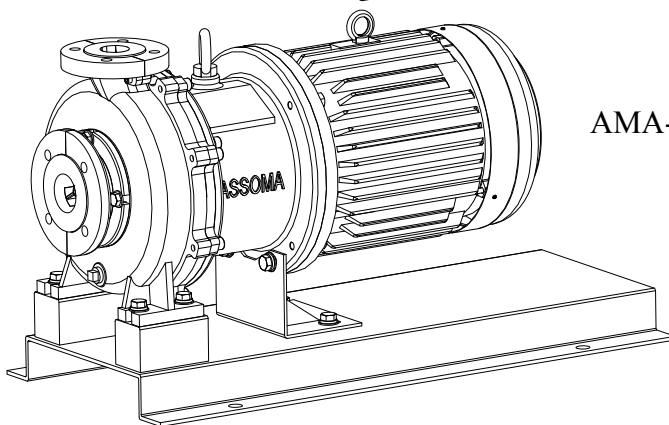

AMA-CT/EP





## Symbols used

	Situation where improper handling or operation failure to follow this manual would almost certainly result in death or serious bodily injury.
---	---

	Situation where improper handling or operation failure to follow this manual could result in death or serious bodily injury.
---	--

	Situation where improper handling or operation failure to follow this manual could result in bodily injury or equipment damage.
---	---

## Table of Contents



1. Foreword .....	3
2. Safety Requirements.....	3
3. Inspecting the Pump Prior to Unpack the Carton/ Install the Pump	4
4. Installation, Piping and Wiring.....	5
5. Notes for Operation .....	9
6. Operating Procedure and Notes.....	1 1
7. Maintenance and Inspection .....	1 3
8. Incorrect Usage and Selection .....	1 5
9. Repair and Warranty .....	1 6
Annex A. Disassembling the AMA-CT/EP Pump .....	1 7
Annex B. Exploded View and Parts List of AMA-CT.....	1 9
Annex C. Exploded View and Parts List of AMA-EP .....	2 0
Annex D. Disassembling the AMA-DT/FP Pump .....	2 1
Annex E. Exploded View and Parts List of AMA-DT.....	2 3
Annex F. Exploded View and Parts List of AMA-FP .....	2 4

## 1. Foreword

Thank you for purchasing an Crest pump. To ensure proper operation and maximum efficiency, please read this instruction manual carefully. Failure to follow the recommended operating conditions outlined in this manual may result in serious personal injuries and/or equipment damage.

## 2. Safety Requirements



This section lists general information about the safety. The relevant safety requirements of installation, wiring, operation and maintenance will set out in the relevant sections. ASSOMA INC. does not assume responsibility for personal danger or property damage resulting from failure to follow the safety instructions contained herein.

 <p><b>DANGER</b></p>	<ol style="list-style-type: none"> <li>1. The explosion-proof grade of AMA series is varied according to materials used together with type of motor matched. Please follow the order specification sheet or contact Crest's local agent.</li> <li>2. Be sure to turn the power off before any wiring or disconnection operations.</li> <li>3. The customer should not modify the pump under any circumstances. Doing so could result in an unexpected accident. Crest shall not be responsible for accidents or damage resulting from equipment modified by the customer.</li> <li>4. Be sure to take special precautions when performing operations if using hazardous, explosive or inflammable liquids.</li> <li>5. Magnetic field hazard: AMA rotor (including the drive magnet and driven magnet) uses strong permanent magnet. Pay attention to potential hazards from powerful magnetic fields to persons, such as, who are assisted by electronic devices.</li> </ol>
 <p><b>WARNING</b></p>	<ol style="list-style-type: none"> <li>1. The pump operator and pump operation supervisor must not allow any operator who has little or no knowledge of the pump to run the pump. Pump operators must have a sound knowledge of the pump and its operation.</li> <li>2. Do not use a damaged pump. Doing so could result in injury or fire.</li> <li>3. Keep away from heat or flame: Do not place any open flame or flammable object near the pump.</li> </ol>
 <p><b>CAUTION</b></p>	<ol style="list-style-type: none"> <li>1. Transport, installation, piping and wiring connections, operation, adjustment, maintenance and inspection should be carried out by qualified personnel. Having unqualified personnel perform these tasks could result in electrical shock, injury or fire.</li> <li>2. Do not block name plate or warning labels for view.</li> <li>3. Do not stand on the pump or use the pump as a step under any circumstances. Otherwise, you may experience a serious injury.</li> <li>4. Disposal of used or damaged pump must be done in accordance with local laws and regulations.</li> </ol>

### 3. Inspecting the Pump Prior to Unpack the Carton/ Install the Pump

- (1) Check the pump exterior for any physical damage that may have been incurred during shipping.
- (2) Use a small screwdriver to rotate the impeller of the motor’s cooling fan. The fan should turn easily. If the fan feels tight or if there are unusual sounds, the interior of the pump may have been damaged during shipping.
- (3) If there is any damage to the pump, contact the shipping company and the distributor immediately to determine who should pay for the damage, and to arrange for replacement parts.
- (4) Each pump has a nameplate, indicating the pump model, MFG number, rated head, flow rate, and motor power, voltage and frequency. Check these data to ensure they comply with your order and application.
- (5) When using versatile motor with 50Hz and 60Hz compliance, be sure to use suitable diameter of impeller according to the frequency of power. A wrong diameter can cause the motor overload (frequency is too high) or insufficient pump performance (frequency is too low).
- (6) The information of nameplates on motor and pump is key for operation setup and pump maintenance. Please keep the nameplate intact for reference.
- (7) The nameplate of a pump indicates the optimum point of its operation. Therein,  
Total Head= Static Head + Dynamic Head.



$$\text{Total Head} = H_s + \frac{V_2^2 - V_1^2}{2g}$$

 <p><b>WARNING</b></p>	<p>The pump is designed and manufactured to the specifications agreed upon by the user and Crest. such as fluid composition, fluid temperature, working pressure, environmental conditions and necessary operational information. Use the pump strictly in accordance with the pump specifications and application range. If the user intends to change any specification, contacts Crest. or the authorized dealer in the near region to obtain the permission in writing before operation.</p>
 <p><b>CAUTION</b></p>	<p>Unpack a pump for inspection without proper hoisting or support of lifting equipment may cause serious personal injury or damage to the pump.</p>

## 4. Installation, Piping and Wiring

### 4.1 Installation Location

- (1) The pump should be close to the ground and located near the inlet tank.
- (2) There should be sufficient space reserved around the pump to facilitate future maintenance and repairs.
- (3) The pump and its wiring should be placed in a relatively dry environment, protected from possible flooding.
- (4) Install in the place where the ambient temperature is not above 40°C.
- (5) Fastening the pump to base plate or machine with anchor bolt.

 <b>WARNING</b>	<ol style="list-style-type: none"> <li>1. Be sure to use the hanger bolt to lift the pump. Do not hang with the other position of the pump. When hoisting, do not pass under a raised pump. A serious injury could occur if the pump is accidentally dropped.</li> <li>2. Before lifting, check the weight of the pump. Do not lift a pump which exceeds the rated weight of the hoist. And, be sure no one standing below the pump while lifting or transporting.</li> </ol>
 <b>CAUTION</b>	<p>Install or store the pump in the following places with special care and consult with ASSOMA INC. or authorized dealer in the near region:</p> <ol style="list-style-type: none"> <li>a. Places where flammable gas, dust or material is used or placed.</li> <li>b. Places where corrosive gas is generated.</li> </ol> <p>Places where the ambient temperature is extremely higher than 40°C or extremely lower than 0°C.</p>

### 4.2 Piping

- (1) AMA flange screw is either M16 or 5/8".
- (2) The allowable load of pipe on the pump.

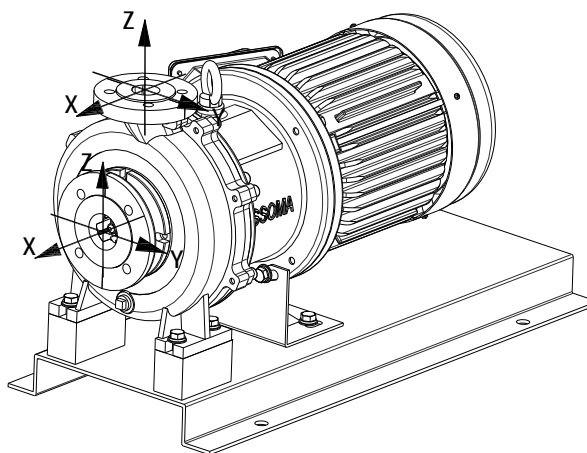

Model	SUCTION							
	Moment (N-m)				力矩(N-m)			
	F <sub>x</sub>	F <sub>y</sub>	F <sub>z</sub>	ΣF	M <sub>x</sub>	M <sub>y</sub>	M <sub>z</sub>	ΣM
AMA-EP	1600	1200	1000	1800	600	500	500	900
AMA-CT	1200	1100	900	1500	600	500	500	900
AMA-DT	1600	1200	1000	1800	600	500	500	900
AMA-FP	1300	1200	1000	2000	700	700	700	1000

Model	DISCHARGE							
	Force (N)				力矩(N-m)			
	F <sub>x</sub>	F <sub>y</sub>	F <sub>z</sub>	ΣF	M <sub>x</sub>	M <sub>y</sub>	M <sub>z</sub>	ΣM
AMA-EP	800	900	1000	1500	600	500	600	800
AMA-CT	800	900	1000	1500	600	500	600	800
AMA-DT	900	1000	1000	1500	700	600	700	1000
AMA-FP	900	1200	1000	1600	700	600	700	1000

### 4.3 Notes for Installing the Piping System

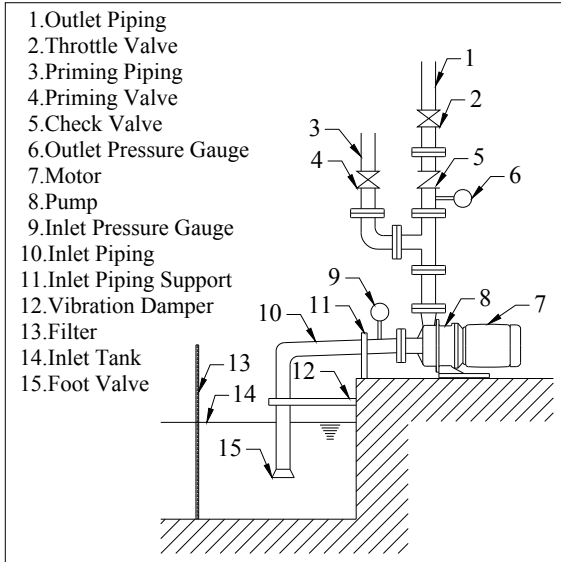

Fig. 4.1

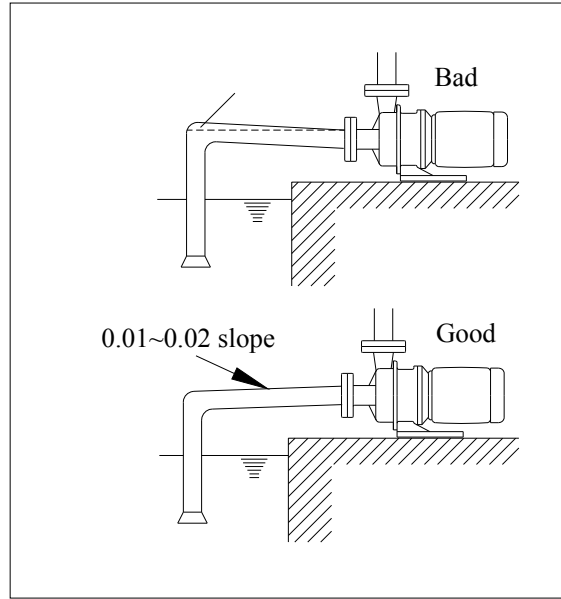

Fig. 4.2

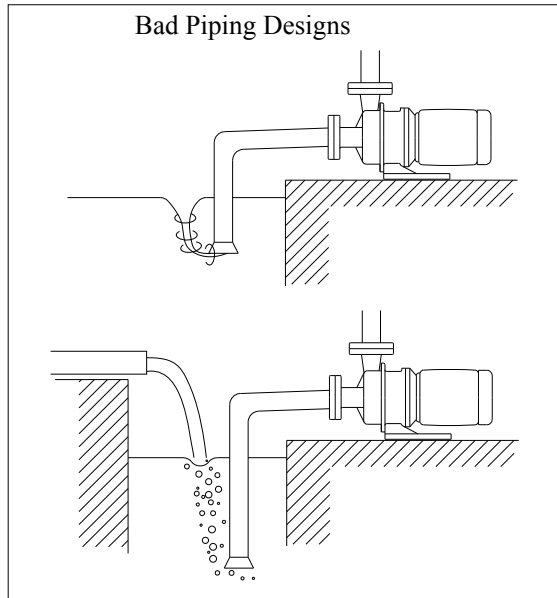

Fig. 4.3

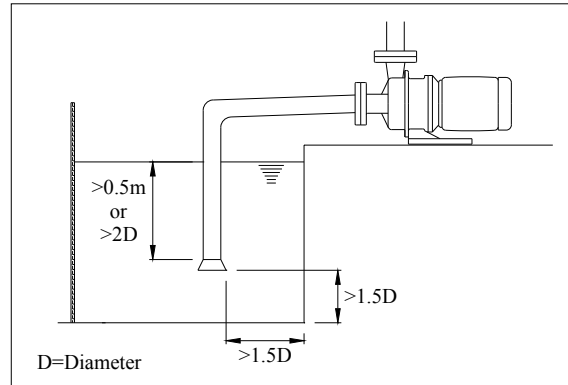



Fig. 4.4

Procedure		Items to Note
<b>Inlet Piping</b>	General Requirements	<ol style="list-style-type: none"> <li>1. Suction condition must satisfy <math>NPSH_a &gt; NPSH_r + 0.5m</math></li> <li>2. Reduce inlet Head as much as possible. Use straight and short piping.</li> <li>3. The pipes should have adequate structural support and shouldn't use the pump as its primary support. (see Fig. 4.1)</li> <li>4. When designing supports, consider the effects of temperature changes on the supports to avoid thermal stress.</li> <li>5. Inlet piping and connectors should be installed properly to prevent sucking in air.</li> <li>6. The piping system should not have upward bumps that may collect air. The inlet piping should also have a 0.01 ~ 0.02 slope increase towards the pump. (see Fig. 4.2)</li> <li>7. There should not be any elbows for at least 5 times the pipe diameter from the opening of the pump. The elbow closest to the pump opening should be a long radial elbow.</li> </ol>
	Inlet Piping	<ol style="list-style-type: none"> <li>1. There should be at least a 1.5 diameter distance between the pipe inlet and the closest tank wall to prevent circulation. (see Fig. 4.4)</li> <li>2. The submerge depth of the inlet should be at least 0.5m or at least twice the pipe diameter below the liquid surface. (see Fig. 4.4)</li> <li>3. There should be a distance of at least 1.5D between the bottom of the tank and the beginning of the inlet pipe opening. (see Fig. 4.4)</li> <li>4. If there are two or more inlet piping in the same tank, they should be placed at least 3D apart to prevent mutually disrupting each other's flow.</li> </ol>
	Foot Valve	Please install a foot valve if upward suction is used. (see Fig. 4.1)
	Self-Priming Cylinder	<ol style="list-style-type: none"> <li>1. If suction method is upward suction, please install a self-priming cylinder to prevent dry-running due to a leaking foot-valve.</li> <li>2. The size of the self-priming cylinder should have a minimum liquid level of at least 0.5m above the opening of the pump.</li> </ol>
	Control Valve	<ol style="list-style-type: none"> <li>1. A control valve should be installed to make disassembling of the pump easier. The valve should only be shut off when the pump is to be detached for maintenance or repairs.</li> <li>2. We recommend the use of valves that have the least loss when fully opened, like a gate valve.</li> </ol>
	Filter	<ol style="list-style-type: none"> <li>1. It is generally not recommended to install a filter in front of a pump, which can unpredictably increase suction system resistance.</li> <li>2. If a filter has to be used, it should be cleaned regularly to ensure a smooth flow.</li> </ol>
	Vacuum Gauge	<ol style="list-style-type: none"> <li>1. The material used should be corrosion resistant; otherwise, a pressure gauge diaphragm should be used.</li> <li>2. During operation, if the vacuum gauge reading fluctuates, either there are air bubbles in the system or cavitation has occurred.</li> </ol>
<b>Outlet Piping</b>	General Requirements	<ol style="list-style-type: none"> <li>1. The weight of the outlet piping should be properly supported to prevent putting excessive stress on the pump. (see Fig. 4.1)</li> <li>2. A priming piping must be installed if the suction system does not employ positive pressure, i.e. upward suction. (see Fig. 4.1)</li> <li>3. The flow rate in the outlet piping should not exceed 3m/sec.</li> <li>4. The ability for each component in the piping system to withstand pressure should be calculated, to determine the maximum allowable operating pressure.</li> </ol>

Procedure	Items to Note
Priming Piping	Upward suction pumps that do not have a self-priming cylinder should have a priming piping system.
Pressure Gauge	<ol style="list-style-type: none"> <li>1. Pressure gauge used should be able to read beyond the maximum operating pressure.</li> <li>2. Pressure gauge should be made of material that is corrosive resistant; otherwise a diaphragm should be used.</li> <li>3. A valve can be installed on the piping that leads to the pressure gauge, to facilitate maintenance and to lengthen the gauge's service life.</li> <li>4. During operation, if the pressure gauge reading fluctuates, either there are air bubbles in the system or cavitation has occurred.</li> </ol>
Check Valve	<p>A check valve should be installed in the following situations:</p> <ol style="list-style-type: none"> <li>1. Outlet piping is long.</li> <li>2. Head of outlet is more than 15m.</li> <li>3. Discharge pressure exceeds 2kg/cm<sup>2</sup> and flow rate exceeds 3m/sec.</li> <li>4. Two or more pumps share the same outlet piping system.</li> <li>5. To prevent back flow (water hammer) from damaging the pump during unexpected power outages.</li> </ol>
Control Valve	<ol style="list-style-type: none"> <li>1. A control valve can be used for controlling the flow of fluids. Do not run the pump with the control valve closed for an extended period of time.</li> <li>2. When starting the pump, always start with a closed valve, and then slowly open the valve to obtain the desired operating pressure and flow. Always open or close the valve gradually.</li> <li>3. To facilitate the adjustment of discharge flow and the adjustment of motor overload, it is recommended to install valves on outlet piping. And if both a check valve and a control valve are to be installed, the order of allocation is pump ⇒ Check Valve ⇒ Control Valve.</li> </ol>
Exhaust Valve	A vent should be installed if the horizontal section of the outlet piping is very long.

	<p>Cautions when dangerous liquids are transferred: When the pumps are used to transfer the dangerous liquids mentioned as below, the pumps, piping and fittings must be checked and watched so that the liquids can not be leaked. Leaking the liquids may result in personal injury and/or explosion, fire accidents.</p> <ol style="list-style-type: none"> <li>a. Explosive and inflammable liquids</li> <li>b. Corrosive and stimulus toxic liquids</li> <li>c. Liquids could directly harm the human body or detrimental to health.</li> <li>d. Liquids could produce a chemical reaction.</li> </ol>
---	---

#### 4.4 Wiring

The wiring system should be done properly, using premium equipment and complying with rules and standards set by the electrical company. The following recommendations should also be implemented:



- (1) Power frequency, voltage and capacity should strictly follow according to motor specification sheet and name plates
- (2) Please select the proper non-fuse switch (NFB) according to the rated current of the motor.
- (3) When using the pump for outdoor applications, please make sure the switch is protected

from rain.

- (4) Keep the electromagnetic contactor (MC) from a pump with suitable distance, and clearly mark warning sign to avoid false start.
- (5) Tags at the end of wires (or diagram shown in the terminal box) and method of connection are based on the number wires (phases), power voltage and mode of start for the motor. Be sure to connect the power cable in accordance with name plate for the motor and the connection diagram in the terminal box
- (6) Select the proper size of wire for power wiring, and tighten screws to prevent loosening. Table 4.1 lists the reference value, and make sure to follow local electrical regulations.

Table 4.1 Wire diameter and terminal locking torque

		minimum diameter	locking torque
7.5Hp	200 ~ 230V	5.5 mm	30 kgf-cm
	380 ~ 480V	2.0 mm	30 kgf-cm
10Hp	200 ~ 230V	8.0 mm	30 kgf-cm
	380 ~ 480V	2.0 mm	30 kgf-cm
15Hp	200 ~ 230V	14.0 mm	30 kgf-cm
	380 ~ 480V	5.5 mm	30 kgf-cm
20Hp	200 ~ 230V	22.0 mm	30 kgf-cm
	380 ~ 480V	8.0 mm	30 kgf-cm
25Hp	200 ~ 230V	30.0 mm	30 kgf-cm
	380 ~ 480V	14.0 mm	30 kgf-cm

 <b>DANGER</b>	<ol style="list-style-type: none"> <li>1. Be sure not to performing any type of maintenance while the power turns on. It may lead to electric shock.</li> <li>2. Power supply and wire connecting work should be performed by qualified personnel only.</li> <li>3. After wiring, be sure to replace the terminal box cover in its original position. Failure to do so could result in electrical shock.</li> </ol>
 <b>WARNING</b>	<ol style="list-style-type: none"> <li>1. Install an earth leakage breaker: The operation of a pump without using an earth leakage breaker may cause an electrical shock. Install an optional leakage breaker in the system before running operation.</li> <li>2. Grounding wire should be consistent with the third type of grounding (grounding resistance is 10Ω or less).</li> <li>3. Each pump must have a separate grounding wire directly connected to the common ground terminal, and must not form a loop between wires.</li> <li>4. If the long wiring results more than 3% voltage drop in the line, replaces with bigger size of wires.</li> </ol>

## 5. Notes for Operation

### 5.1 Dry-Running

- (1) Our pump use the transfer fluid as its internal cooling system, therefore, dry-running the pump can cause the temperature to rise to a dangerous level that may seriously damage the pump.

- (2) If dry-running occurs, switch off the pump immediately; let it cool for at least an hour before priming the pump to prepare it for normal operation.

**NOTE:** Do not subject the pump to rapid cooling, which may damage the internal parts.

- (3) We recommend using a dry-run protector to detect dry-run occurrences to avoid causing unnecessary damage to the pump.

## 5.2 Operating Temperature

- (1) Operating temperature may change the fluid's viscosity, vapor pressure, and corrosiveness. Please ensure that your pump is operating within the proper temperature range.
- (2) The optimal temperature range for pumping pure water:  
Body material ETFE+CF: 0°C ~ 90 °C
- (3) Please consult the distributor for the temperature range suitable for your chemicals.
- (4) We recommend the operating environmental temperature to be between 0°C ~ 40 °C.

	<p>When the pump is used to feed a hot liquid, do not touch the front cover or the piping with your bare hands. It may cause burns. Any reachable hot surfaces, including pumps, motors and piping, must provide isolate device and display obvious warning signs for high temperature.</p>
--	---

## 5.3 Concentrations, Viscosity and Specific Gravity

- (1) A change in a fluid's concentration will usually affect its viscosity and specific gravity. Other physical properties like corrosiveness, may also change with the fluid's concentration, therefore, the selected pump material should be able to withstand the corrosive properties of the fluid.
- (2) When the fluid's viscosity and/or specific gravity differ from that of water, the shaft power, flow rate and pump head may change also.

## 5.4 Particle Size (Sludge)

- (1) The service life of a pump can be greatly shortened by pumping fluids that carry small particles or sludge. Its service life is dependent on the concentration of the particles, its size, and hardness.
- (2) For particle concentration less than 5%, particle size smaller than 50µm, and hardness within 80Hs, which has SiC bushings, can be used. However, a shorter-than-normal service life can be expected.

	<p>Should foreign matter enter the pump, it may cause pump damage or failure. Turn off the power at once and remove the obstruction.</p>
---	--

## 5.5 Maximum Operating Pressure

The pump's maximum operating pressure is dependent on the operating temperature and the structure of the pump. Please refer to figure 5.1 for the recommended maximum operating pressure for our AMA pumps.

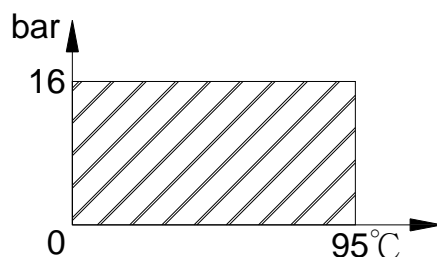

Figure 5.1 AMA allowable working pressure

## 5.6 Minimum Flow

Our pumps use the pumped fluid as their cooling and lubricating system. A low flow rate may result in increasingly high temperature within the pump, and increased radial and axial force, thus, affecting the pump's performance and service life. Please use table 5.1 for the recommended minimum flow rate:

Table 5.1

Unit: L/min

Temperature (°C)	40°C	60°C	80°C	95°C
Model				
AMA-CT	60	80	100	120
AMA-EP	80	100	120	150
AMA-DT	80	100	120	150
AMA-FP	100	120	150	180

Note: 1. Above data is based on water. For volatile or viscous fluids, please consult your local distributor.

2. Please do not operate the pump under minimum flow rate over one minute.

 <b>CAUTION</b>	Do not operate the pump with outlet valve shut off more than one minute. Long time shut off will cause the inside to heat up and damage the pump.
---	---

## 6. Operating Procedure and Notes

### 6.1 Notes Prior to Starting the Pump

- (1) Check the motor's power rating, including frequency, voltage and wiring.
- (2) Recheck to make sure all the parts (flange, pump casing, base plate, etc.) are securely

fastened.

- (3) Fill the pump with liquid (priming) to remove any air within the pump and suction piping.
- (4) Check to ensure the inlet valve is open.
- (5) Using a screwdriver, rotate the motor's cooling fan to ensure it is not too tight or stuck.

## 6.2 Starting Up the Pump

- (1) Check the direction of rotation of the motor by rapidly switching on and off the power.
- (2) Direction of motor rotation can be checked from the fan side. It should be clockwise seeing from the fan cover (follow arrow direction on the fan cover). If the rotating direction reverses, change wiring phases by shifting any two wire connections.
- (3) Close the outlet valve and start up the pump.
- (4) Slowly open the outlet valve when the motor has reached a stable speed. Adjust the outlet valve to obtain the desired operating pressure or flow rate.

## 6.3 Operating the Pump

- (1) Shut down the pump immediately in the case of cavitation or dry-running.
- (2) If decoupling should happen, shut down the pump to prevent reducing the magnet's strength.
- (3) During power outages, shut off the pump's power supply and close the outlet valve.
- (4) When switching on the pump with the outlet valve closed, the outlet pressure should increase. If the pressure fails to rise, or if the pressure is too low, shut down the pump and check the piping and wiring.

**NOTE:** Outlet Pressure = Inlet Pressure + Pump Pressure

$$\text{Pump Pressure (kg/cm}^2\text{)} = \text{Fluid Specific Gravity} * \text{Pump Head} / 10$$

## 6.4 Shutting Down the Pump

- (1) Close the outlet valve slowly to prevent damage to the pump due to reverse fluid flow (water hammer).
- (2) Shut off the pump. It should stop gradually. If not, check the interior of the pump for problems.
- (3) The pump should be checked periodically. If the pump is used in a cold operating environment (relative to the fluid's freezing point), the fluid may crystallize even if the pump is shut down for a very short amount of time. To prevent crystallization, a drain plug should be included in the piping system or a heating system could be used to maintain the temperature during shutdown.

## 7. Maintenance and Inspection

### 7.1 Daily Inspection

Table 7.1

<b>Appearance</b>	<ol style="list-style-type: none"> <li>1. Check for oxidation or corrosion of the front casing, bracket, and base plate.</li> <li>2. Check for leakage of the pump and the piping system.</li> <li>3. Check the pump exterior for any physical damage such as corrosion, paint stripped off.</li> </ol>
<b>Operation</b>	<ol style="list-style-type: none"> <li>1. Check for irregular sounds and vibrations.</li> <li>2. Check any abnormal overheat on the surface of motor, three-phase current is imbalanced, bearing noise, foreign material blocking the vent of fan.</li> <li>3. Check the in-tank fluid levels and inlet/outlet pressures.</li> <li>4. Check the current and motor loading.</li> <li>5. Check and test-run backup pumps regularly to ensure they can function properly when needed.</li> </ol>

### 7.2 Periodic Maintenance

- (1) The following items should be inspected quarterly referring to table 7.2.
- (2) Pump's disassembly, assembly and notes to be attended refer to Annex A.

Table 7.2

<b>Part Name</b>	<b>Inspection Item</b>	<b>Solution</b>
<b>Front and rear casing</b>	<ol style="list-style-type: none"> <li>1. Cracks.</li> <li>2. Scratch marks (except when pumping particle laden fluids).</li> <li>3. Crystallization or sludge.</li> <li>4. Shaft support loose or deformed.</li> </ol>	<ol style="list-style-type: none"> <li>1. Replace.</li> <li>2. Contact the distributor.</li> <li>3. Clean.</li> <li>4. Contact distributor.</li> </ol>
<b>Front casing o-ring</b>	Deformed, corroded or swollen.	Replace
<b>Impeller and magnet assembly</b>	<ol style="list-style-type: none"> <li>1. Scratch marks or cracks.</li> <li>2. Cracked bearing or crystallization.</li> <li>3. Bearing displays signs of some wear and tear.</li> <li>4. Crystallization and other sludge.</li> <li>5. Foreign objects stuck in impeller.</li> <li>6. Impeller deformed.</li> </ol>	<ol style="list-style-type: none"> <li>1. Contact distributor.</li> <li>2. Contact distributor.</li> <li>3. Replace if worn excessively.</li> <li>4. Clean.</li> <li>5. Remove the objects.</li> <li>6. Contact distributor.</li> </ol>
<b>Shaft and thrust ring</b>	<ol style="list-style-type: none"> <li>1. Scratch marks.</li> <li>2. Cracks.</li> </ol>	<ol style="list-style-type: none"> <li>1. Contact distributor.</li> <li>2. Replace.</li> </ol>
<b>Motor</b>	<ol style="list-style-type: none"> <li>1. Resistance of three phases and insulation impedance.</li> <li>2. Check amount of lubricant when using open bearing.</li> </ol>	<ol style="list-style-type: none"> <li>1. Repair or change if abnormal is found.</li> <li>2. Keep amount of lubricant at proper level.</li> </ol>

### 7.3 Maintenance and wear/tear limits

Maintain the magnetic pumps by controlling the wearing parts like bearing, shaft, thrust ring and wear ring.

To avoid damages at the pump, we recommend, controlling the wearing gap limit between bearing and shaft not exceed 0.8mm, while between thrust ring and wear ring not exceed 1.0mm. You need only to change one of parts with heavier wear and tear.

During disassembly of the magnetic pump the dimensions of following components should be checked:

Table 7.3 Unit: mm

Model	Dimension		New part	Time to change
	Part			
AMA-CT/EP	Shaft outer diameter		28	27.2
	Bearing inner diameter		28	28.8
	Thrust ring thickness		7	6
	Wear ring thickness		7	6
AMA-DT/FP	Shaft sleeve outer diameter		38	37.6
	Bearing inner diameter		38.1	38.5
	Thrust ring thickness		10	9.2
	Wear ring thickness		10	9.2

### 7.4 Preventive Maintenance



Operational data, like vibration, flow rate, voltage, etc. can be collected, and upper and lower limits can be set for each of the values. The collected data can be used for trend analysis (see Fig. 7.1), which can be a basis in which to determine when to carry out preventive maintenance.

The vibration value should be lower than 4.5mm/sec (RMS)(measured on the surface of bracket), and the noise level should be below 85dB (at operating point).

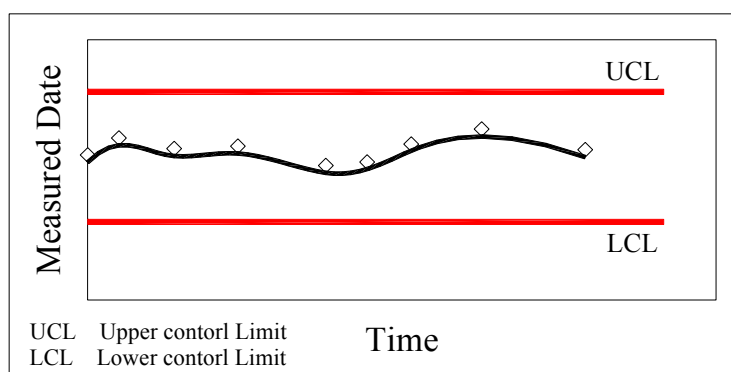
Figure 7.1



	<ol style="list-style-type: none"> <li>1. AMA's powerful permanent magnetic coupling could adversely affect persons who are assisted by electronic devices such as pacemaker.</li> <li>2. Be sure to turn the power off before performing any type of maintenance, repair or inspection. Make special provisions so that no other operator mistakenly turns on the power supply while someone is working on the pump. In a noisy or poor visibility environment, display a sign near the power supply switch to notify others that someone is "WORKING" on the pump. Power supply mistakenly turned on during maintenance may lead to</li> </ol>
---	--

 <p><b>WARNING</b></p>	<p>personal injury.</p> <ol style="list-style-type: none"> <li>1. When handling a toxic or odorant liquid, ventilate the working area well. In addition, the operator must wear protector gear (such as a safety mask, safety goggles, and protective gloves).</li> <li>2. No remodeling: Remodeling of the pump by the user may result in serious injury, electric shock, or damage to the pump. Do not attempt to remodel as it is very dangerous.</li> <li>3. Magnetic field hazard: Be careful not to get your hands or fingers pinched by parts. Impeller is encapsulated strong magnet inside. While, do not let the magnet close to the magnetic sensitive objects such as magnetic cards, computer equipment, etc.</li> </ol>
 <p><b>CAUTION</b></p>	<ol style="list-style-type: none"> <li>1. Use the right tools for any maintenance or disassembly and assembly.</li> <li>2. Be careful with hazardous liquids: If pumping dangerous chemicals, be sure to drain and wash well before disassembling. A small amount of fluid may however remain in the internal parts or pipe fittings.</li> </ol>

## 8. Incorrect Usage and Selection

	<b>Abnormal Condition</b>	<b>Possible Effect/Damage</b>
<b>Incorrect System Calculations or Incorrect Pump Selected</b>	System resistance too high or pump head too low	<ol style="list-style-type: none"> <li>1. Insufficient or no flow.</li> <li>2. Pump unable to effectively dissipate heat.</li> <li>3. Excessive wear on bearing and thrust rings.</li> </ol>
	Resistance lower than expected or pump head too high	<ol style="list-style-type: none"> <li>1. Excessive flow.</li> <li>2. Overloading of the motor.</li> <li>3. NPSHa too low, resulting in cavitation.</li> </ol>
	NPSHa too low, resulting in cavitation	<ol style="list-style-type: none"> <li>1. High frequency vibration and noise.</li> <li>2. Fracturing of the bearing and thrust rings.</li> <li>3. Decreased pump performance and low flow rate.</li> <li>4. Serious cases may result in dry-running.</li> </ol>
	Specific gravity higher than anticipated	<ol style="list-style-type: none"> <li>1. Motor overloading.</li> <li>2. Decoupling of the magnetic drive.</li> </ol>
	Viscosity higher than anticipated	<ol style="list-style-type: none"> <li>1. Motor overloading.</li> <li>2. Decoupling of the magnetic drive.</li> <li>3. Decreased pump performance and reduced flow.</li> </ol>
	Wrong pump material selected	<ol style="list-style-type: none"> <li>1. Corrosion and cracking.</li> <li>2. Rapid corrosion and wearing of bearing.</li> <li>3. Corrosion of the O-ring resulting in leakage.</li> </ol>
<b>Improper Piping or Layout</b>	Inlet pipe not submerged sufficiently into the fluid or air sucked into piping system	<ol style="list-style-type: none"> <li>1. Produce high frequency vibrations and noise.</li> <li>2. Fracturing of the bearing and thrust rings.</li> <li>3. Reduced pump performance.</li> <li>4. Serious cases can lead to dry-running.</li> </ol>
	Air pockets in inlet piping	<ol style="list-style-type: none"> <li>1. Reduced pump performance.</li> <li>2. Serious cases can lead to dry-running.</li> </ol>
	Parallel pumps improperly installed	Improper suction, resulting in low efficiency, insufficient flow, cavitation or dry-running.
	Leaking foot valve or inlet piping	Fluids within pump leaks during shut-down period, resulting in dry-running when pump is restarted.

	<b>Abnormal Condition</b>	<b>Possible Effect/Damage</b>
<b>Improper Operation</b>	Starting the pump without priming	Dry-running, causing damage to pump.
	Low speed or wrong rotation direction	Low fluid flow.
	Incorrect motor frequency or voltage	Overloading of the motor.
	Low inlet tank fluid level	1. Low performance and vibrations caused by sucked-in air. 2. Fracturing of the bearing and thrust rings. 3. Dry-running.
	Foreign objects stuck in impeller	1. Produce vibrations and noise. 2. Reduced efficiency and flow. Serious cases may result in dry-running.
	Low flow over extended period of time	1. Insufficient cooling of pump. 2. Excessive radial and axial force, reducing service life of bearing and thrust rings.
	Inlet valve closed	Dry-running, seriously damaging the pump.
	Transfer fluid temperature too high	1. Low NPSHa, resulting in cavitation. 2. Reduced strength of the magnet, resulting in decoupling.
	Fluid carries hard particles	1. Rapid wearing of the bearing. 2. Wearing of the impeller and casing surfaces.
<b>Improper Maintenance</b>	Deformation of the o-ring	Result in leakage.
	Damaged impeller	1. Resulting in vibrations and noise. Reduced pump performance and fluid flow.
	Damaged motor bearings	1. Produce vibrations and noise. 2. Overloads the motor. High Motor temperature.
	Wear ring worn off	1. Produce vibrations and noise. Overloads the motor.
	Wearing of the impeller bearings	1. Produce vibrations and noise. May result in fracturing of the impeller shaft.
	Pump's base screws loose	Produce vibrations and noise.

## 9. Repair and Warranty

When a problem arises, please read this instruction manual and try to troubleshoot the problem. If the problem cannot be found, or if replacement parts are needed, please call the distributor, and give them the following information:

- (1) The pump model and manufacturing serial number indicated on the nameplate.
- (2) The operating condition.
- (3) The situation under which the pump fails.

Please refer to the warranty card for details of the warranty terms and conditions.

## Annex A. Disassembling the AMA-CT/EP Pump

- a. The magnets used in our AMA-CT & EP magnetic drive seal-less pumps have very strong magnetic strength. Take extra precautions when disassembling the pump to prevent personal injury and damage to electronic and magnetic equipments (like diskettes, magnetic stripe cards, etc.).
- b. For personal safety, wear protective gear, like corrosive resistant aprons and protective eyeglasses during disassembly, to prevent injuries caused by spilled chemicals.
- c. Please follow the reverse procedure for disassembly to assemble the AMA-CT & EP pump:

Note: Following steps are for periodic maintenance or repair under abnormal condition.

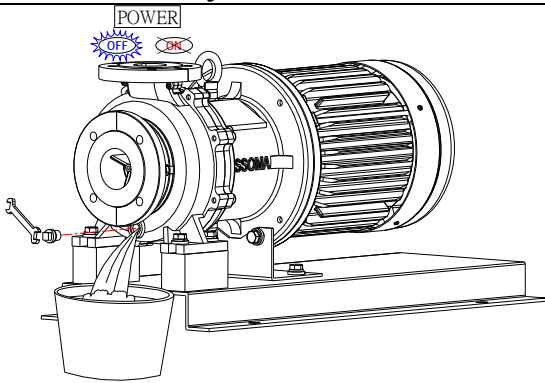
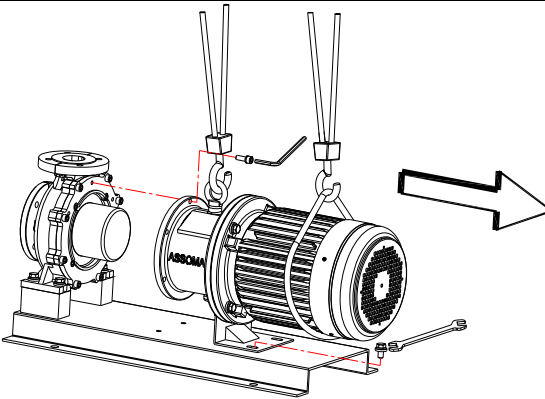
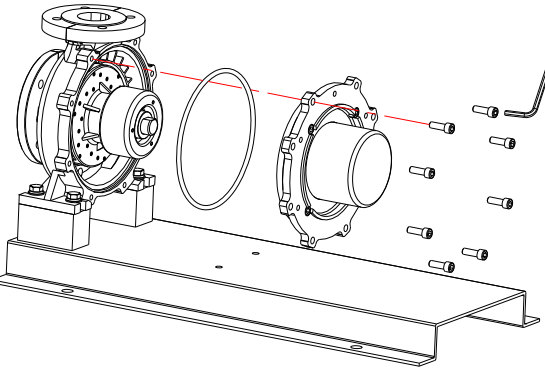
<b><i>Pump disassembly</i></b>		
<b>Step 1</b>		<ol style="list-style-type: none"> <li>1. Switch off power.</li> <li>2. Shut off inlet &amp; outlet valves.</li> <li>3. Use #12 open-end wrench to unscrew the drain plug.</li> <li>4. Drain the pump and use proper container to keep the liquid.</li> </ol> <p><b>⚠ For personal safety, wear protective gear, like corrosive resistant aprons, gloves and protective eyeglasses during disassembly.</b></p>
<b>Step 2</b>		<ol style="list-style-type: none"> <li>1. Dismount pump head by unscrew M12x25L hex. screws and M10x30L inner hex. screws.</li> <li>2. Hoist motor and bracket to pull out from the pump head.</li> </ol> <p><b>⚠ Place the motor safely with suitable support to prevent the danger of tumbling.</b></p>
<b>Step 3</b>		<ol style="list-style-type: none"> <li>1. Unscrew inner hex. screws M10x30L.</li> <li>2. Dismount backup plate and rear casing.</li> <li>3. Remove o-ring.</li> </ol> <p><b>⚠ (1) Be aware of the safety of person and the pollution of the liquid. The liquid left inside the pump will leak or flow out of the pump when the backup plate is disassembled.</b></p> <p><b>(2) When take off Backup Plate, use your finger against the Impeller to prevent it dismantled together and cause damage.</b></p>

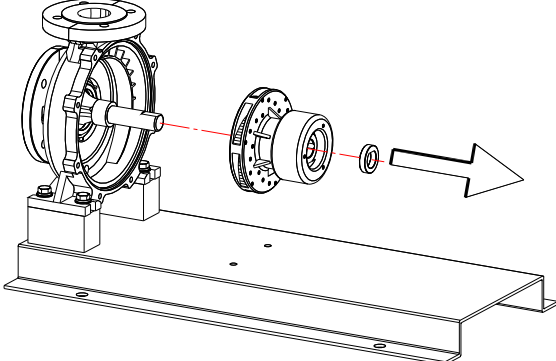
<p><b>Step 4</b></p>		<ol style="list-style-type: none"> <li>1. Dismount impeller magnet bearing assembly and rear thrust ring.</li> <li>2. For <u>AMA-CT</u> series: Buffer thrust ring assembly, shaft and front shaft support can be dismantled.</li> </ol> <p><b>⚠ Pull out Impeller from the Shaft carefully. Don't separate the parts forcibly to prevent breakage.</b></p>
<p><b>Items to check</b></p>	<ul style="list-style-type: none"> <li><input type="checkbox"/> Inner magnet being demagnetization or swollen?</li> <li><input type="checkbox"/> Wear and tear of bearing and wearing ring?</li> <li><input type="checkbox"/> Any corrosion being detected on the wetted parts?</li> </ul>	<ul style="list-style-type: none"> <li><input type="checkbox"/> Any deformation or imbedded particles on the Impeller?</li> <li><input type="checkbox"/> Any crack on Thrust Ring and Shaft?</li> <li><input type="checkbox"/> Any scratch mark being detected on impeller, front casing and rear casing?</li> </ul>

# Annex B. Exploded View and Parts List of AMA-CT

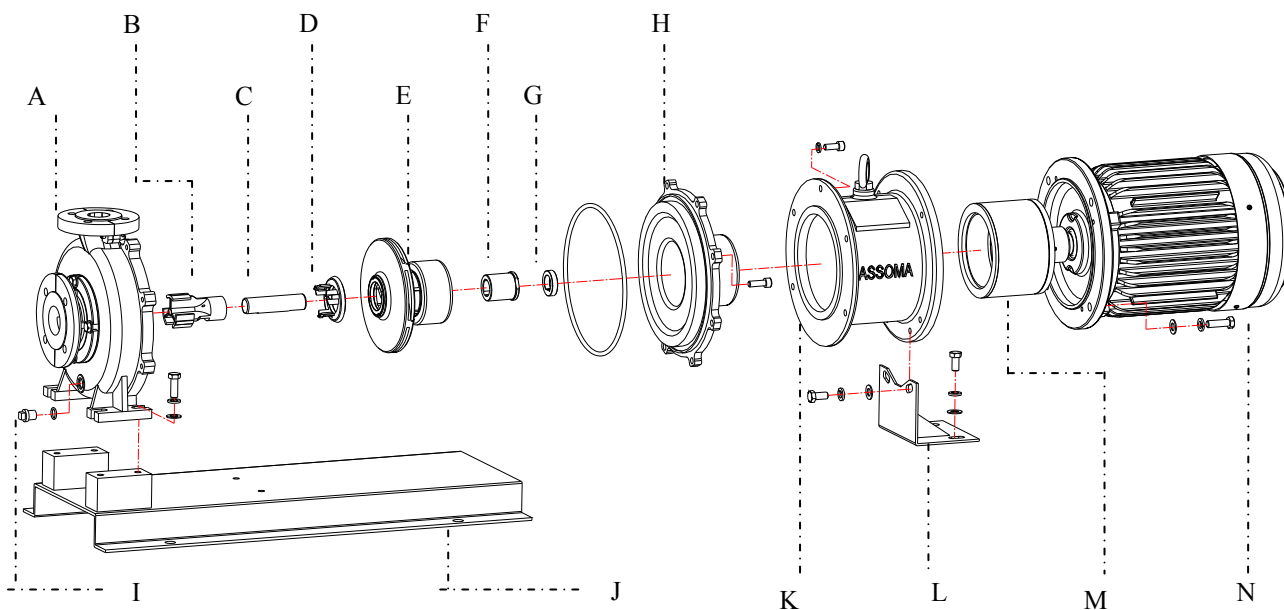

	No.	Part	Material
A	101	Pump casing	ETFE+CF
	155.01	Casing armour	FCD
	155.02	Inlet armour	FCD
	155.03	Outlet armour	FCD
B	220	Front support, Shaft	ETFE+CF
C	211	Shaft	SSiC/CERAMIC
D	319	Front buffer	ETFE
		Front thrust ring	SSiC/CERAMIC
E	230	Front wear ring	SSiC/CARBON
		Impeller	ETFE+CF
	847	Magnet capsule	ETFE, Nd-Fe-B
F	310	Bearing	SSiC/CARBON
G	S34	Rear thrust ring	SSiC/CERAMIC
H	161.01	Rear casing with cover	ETFE+CF, CARBON FRP
	161.02	Backup plate	FCD
I	912	Drain plug	ETFE+CF
J	B11	Base	SUS304
K	181	Bracket	FC
L	183	Bracket foot	SUS304
M	M01	Drive magnet	Na-Fe-B
N	EM	Motor	FC/Aluminum Alloy
	RG	O-ring	VITON/PEM

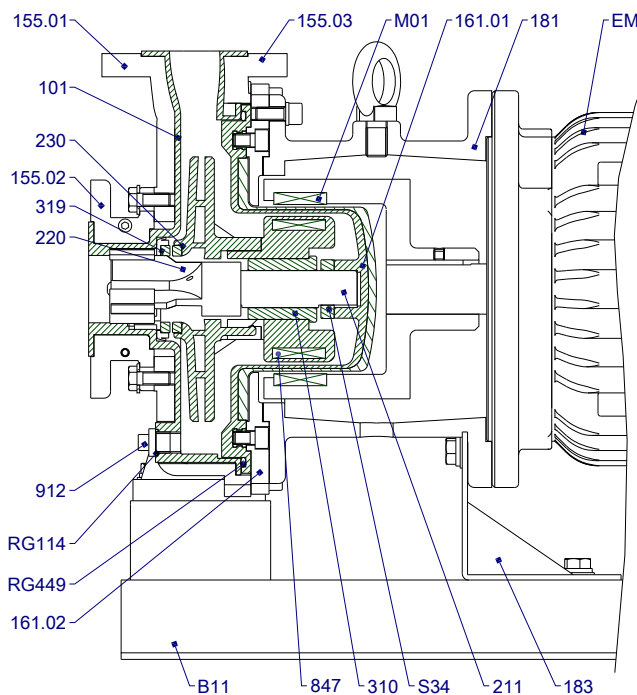

## Annex C. Exploded View and Parts List of AMA-EP

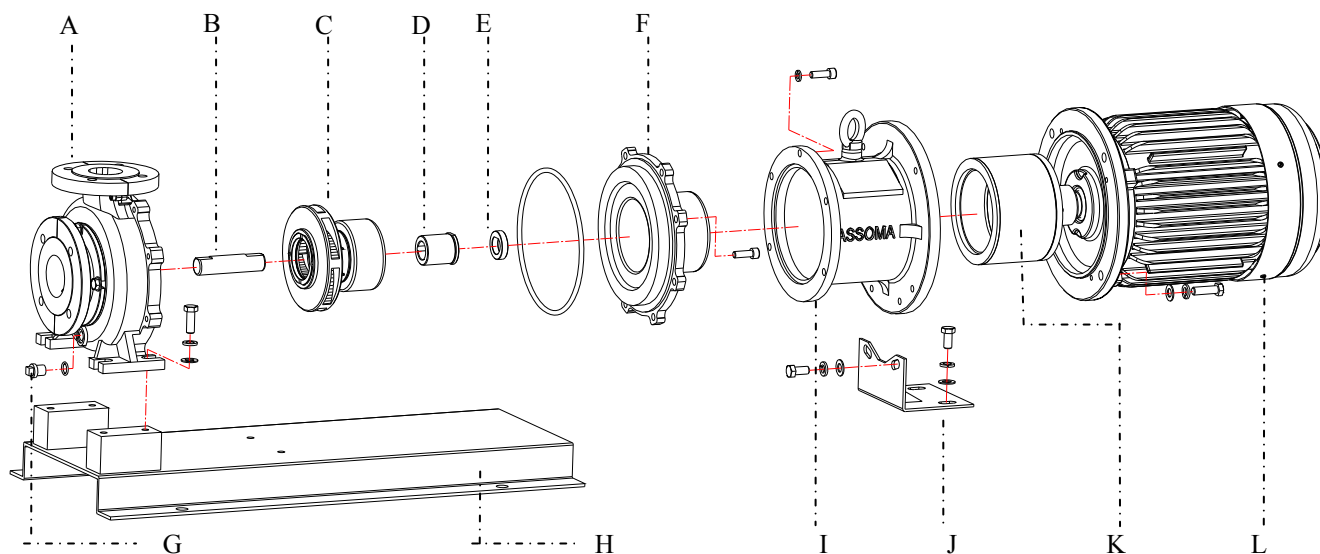

	No.	Part	Material
A	101	Pump casing	ETFE+CF
		Front support, shaft	ETFE+CF
		Front thrust ring	SSiC/CERAMIC
	155.01	Casing armour	FCD
	155.02	Inlet armour	FCD
	155.03	Outlet armour	FCD
B	211	Shaft	SSiC/CERAMIC
C	230	Front wear ring	SSiC/CARBON
	847	Magnet capsule	ETFE, Nd-Fe-B
D	310	Bearing	SSiC/CARBON
E	S34	Rear thrust ring	SSiC/CERAMIC
F	161.01	Rear casing with cover	ETFE+CF, CARBON FRP
	161.02	Backup plate	FCD
G	912	Drain plug	ETFE+CF
H	B11	Base	SUS304
I	181	Bracket	FC
J	183	Bracket foot	SUS304
K	M01	Drive magnet	Nd-Fe-B
L	EM	Motor	FC/Aluminum Alloy
	RG	O-ring	VITON/EPDM

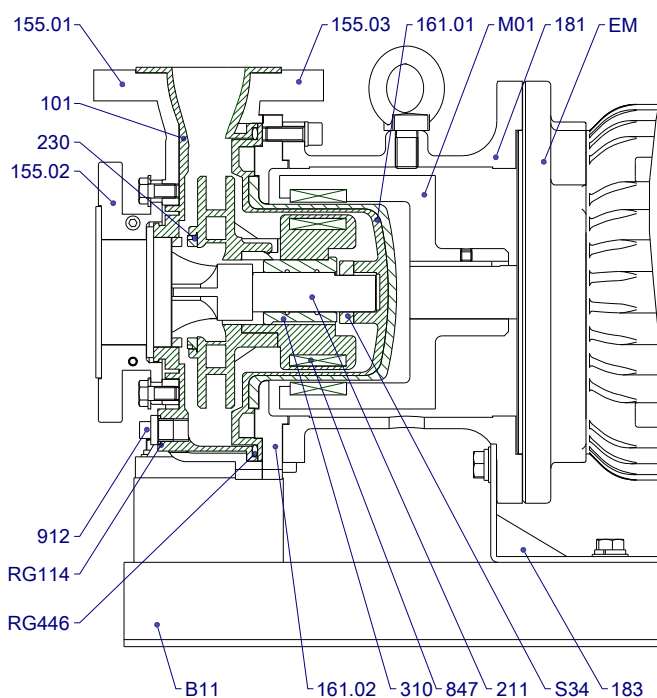

## Annex D. Disassembling the AMA-DT/FP Pump

- d. The magnets used in our AMA-DT/FP magnetic drive seal-less pumps have very strong magnetic strength. Take extra precautions when disassembling the pump to prevent personal injury and damage to electronic and magnetic equipments (like diskettes, magnetic stripe cards, etc.).
- e. For personal safety, wear protective gear, like corrosive resistant aprons and protective eyeglasses during disassembly, to prevent injuries caused by spilled chemicals.
- f. Please follow the reverse procedure for disassembly to assemble the AMA-DT/FP pump:

Note: Following steps are for periodic maintenance or repair under abnormal condition.

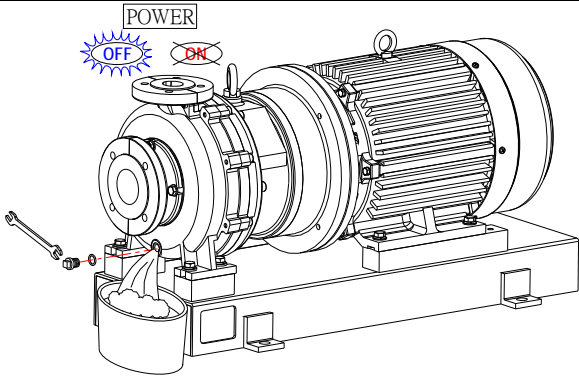
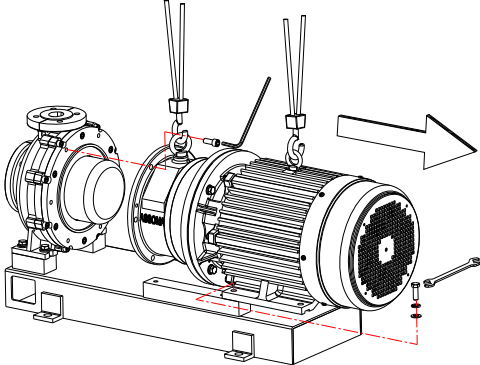
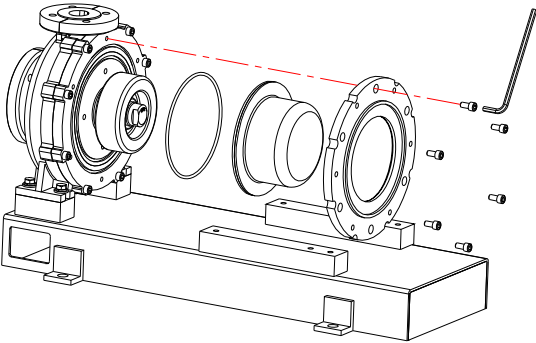
<b><i>Pump disassembly</i></b>	
<b>Step 1</b>	 <div style="display: flex; justify-content: space-between;"> <div style="width: 45%;"> <ol style="list-style-type: none"> <li>1. Switch off power.</li> <li>2. Shut off inlet &amp; outlet valves.</li> <li>3. Use #12 open-end wrench to unscrew the drain plug.</li> <li>4. Drain the pump and use proper container to keep the liquid.</li> </ol> <p><b>⚠ For personal safety, wear protective gear, like corrosive resistant aprons, gloves and protective eyeglasses during disassembly.</b></p> </div> <div style="width: 50%; padding-left: 20px;"> <ol style="list-style-type: none"> <li>1. Switch off power.</li> <li>2. Shut off inlet &amp; outlet valves.</li> <li>3. Use #12 open-end wrench to unscrew the drain plug.</li> <li>4. Drain the pump and use proper container to keep the liquid.</li> </ol> <p><b>⚠ For personal safety, wear protective gear, like corrosive resistant aprons, gloves and protective eyeglasses during disassembly.</b></p> </div> </div>
<b>Step 2</b>	 <div style="display: flex; justify-content: space-between;"> <div style="width: 45%;"> <ol style="list-style-type: none"> <li>1. Dismount pump head by unscrew M12x30L hex. screws and M12x40L inner hex. screws.</li> <li>2. Hoist motor and bracket to pull out from the pump head.</li> </ol> <p><b>⚠ Place the motor safely with suitable support to prevent the danger of tumbling.</b></p> </div> <div style="width: 50%; padding-left: 20px;"> <ol style="list-style-type: none"> <li>1. Dismount pump head by unscrew M12x30L hex. screws and M12x40L inner hex. screws.</li> <li>2. Hoist motor and bracket to pull out from the pump head.</li> </ol> <p><b>⚠ Place the motor safely with suitable support to prevent the danger of tumbling.</b></p> </div> </div>
<b>Step 3</b>	 <div style="display: flex; justify-content: space-between;"> <div style="width: 45%;"> <ol style="list-style-type: none"> <li>1. Unscrew inner hex. screws M10x20L.</li> <li>2. Dismount backup plate and rear casing.</li> <li>3. Remove o-ring.</li> </ol> <p><b>⚠ If the transmission fluid in the pump is not discharged completely, when unlock the screws on the back cover, the liquid will start to leak. Please pay attention to the staff's safety and the pollution to environment.</b></p> </div> <div style="width: 50%; padding-left: 20px;"> <ol style="list-style-type: none"> <li>1. Unscrew inner hex. screws M10x20L.</li> <li>2. Dismount backup plate and rear casing.</li> <li>3. Remove o-ring.</li> </ol> <p><b>⚠ If the transmission fluid in the pump is not discharged completely, when unlock the screws on the back cover, the liquid will start to leak. Please pay attention to the staff's safety and the pollution to environment.</b></p> </div> </div>

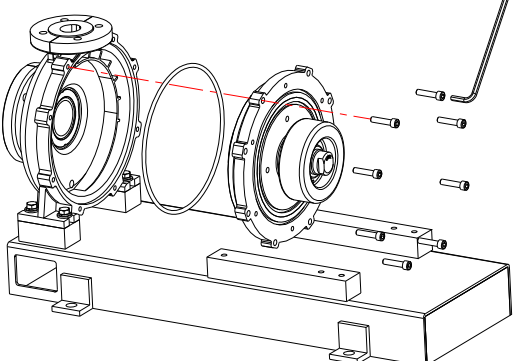
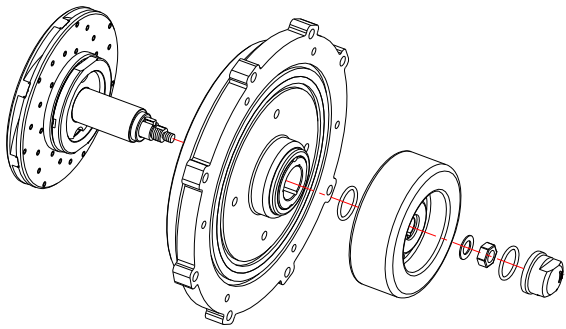
<p><b>Step 4</b></p>		<ol style="list-style-type: none"> <li>1. Take off Inner Hex. Screws M10x40L. assembly and rear thrust ring.</li> <li>2. Dismount bearing frame, impeller assembly and o-ring.</li> </ol>
<p><b>Step 5</b></p>		<ol style="list-style-type: none"> <li>1. Unscrew shaft nut clockwise.</li> <li>2. Remove o-ring, nut and washer. (The tightening torque between nut and Shaft is 100N-m).</li> <li>3. Remove inner magnet and o-ring.</li> <li>4. Dismount impeller, shaft sleeve and bearing frame, then, remove shaft sleeve.</li> </ol> <p><b>⚠ Parts to be separated, such as, bearing frame with impeller/shaft sleeve, don't separate the parts forcibly to prevent breakage.</b></p>
<p><b>Items to check</b></p>	<ul style="list-style-type: none"> <li><input type="checkbox"/> Inner magnet being demagnetization or swollen?</li> <li><input type="checkbox"/> Wear and tear of bearing and wearing ring?</li> <li><input type="checkbox"/> Any corrosion being detected on the wetted parts?</li> </ul>	<ul style="list-style-type: none"> <li><input type="checkbox"/> Any deformation or imbedded particles on the Impeller?</li> <li><input type="checkbox"/> Any crack on thrust ring and shaft?</li> <li><input type="checkbox"/> Any scratch mark being detected on impeller, front casing and rear casing?</li> </ul>

# Annex E. Exploded View and Parts List of AMA-DT

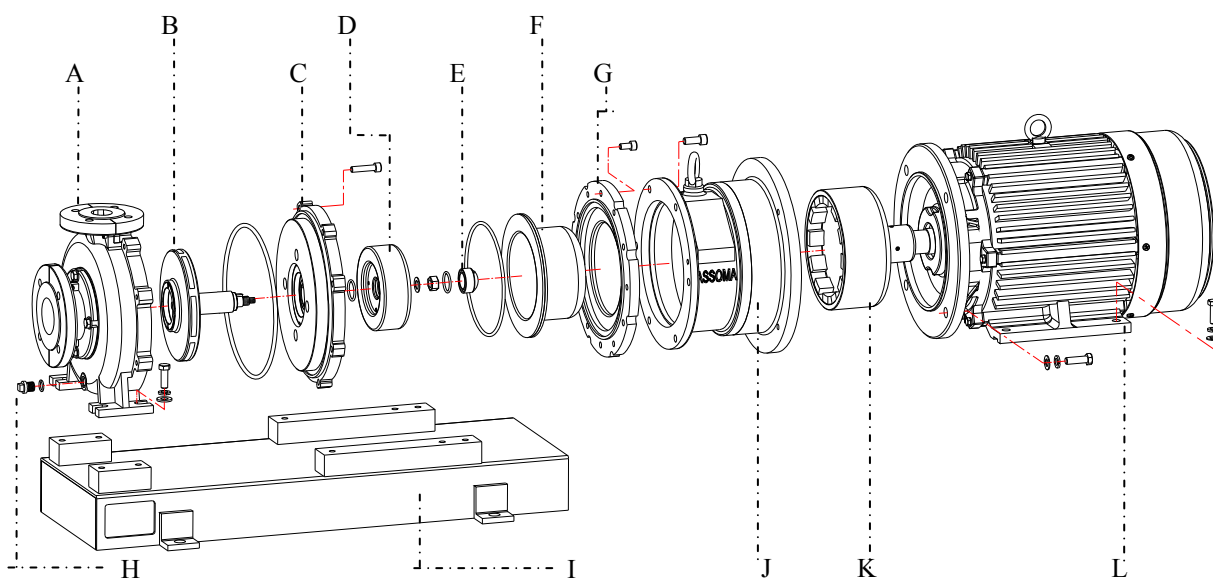

No.	Part	Material
A	101 Pump casing	ETFE+CF
	Front thrust ring	SSiC/CERAMIC
	155.01 Casing armour	FCD
	155.02 Inlet armour	FCD
B	230 Impeller	ETFE+CF
	Front wear ring	SSiC/CARBON
	Rear wear ring	SSiC/CARBON
	211 Shaft	SUS316
C	523 Shaft sleeve	SSiC/CERAMIC
	343 Bearing frame	FC- ETFE+CF
	310 Bearing	SSiC/CARBON
D	847 Magnet capsule	ETFE, Nd-Fe-B
E	920 Nut & washer	SUS316
	921 Shaft nut	ETFE
F	161.01 Rear casing with cover	ETFE+CF, CARBON FRP
G	161.02 Backup plate	FCD
H	912 Drain plug	ETFE+CF
I	890 Base	SUS304
J	181 Bracket	FC
	B22 Bracket adapter	FC
K	M01 Drive magnet	Nd-Fe-B
L	EM Motor	FC/Aluminum
RG	O-ring	VITON/EPDM

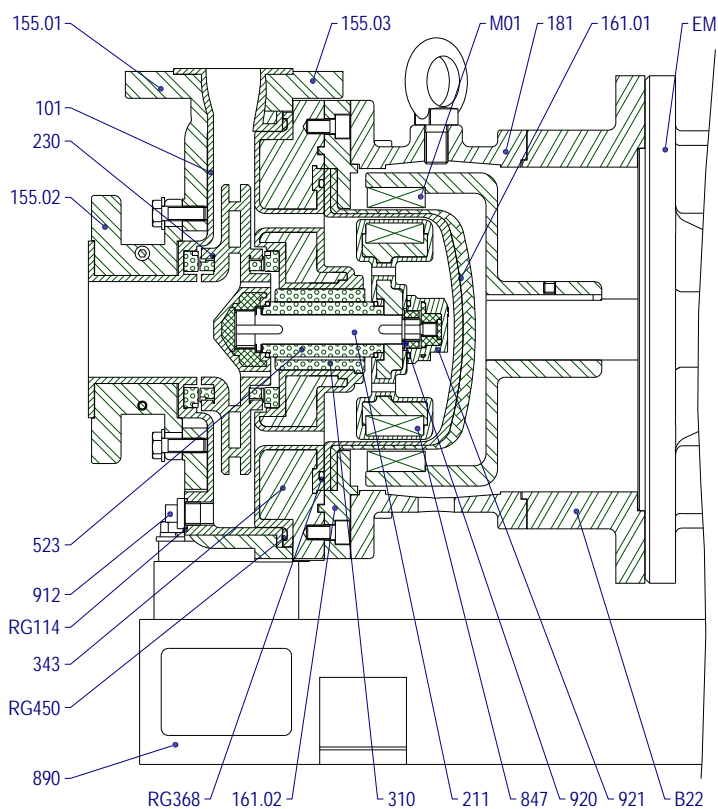

# Annex F. Exploded View and Parts List of AMA-FP

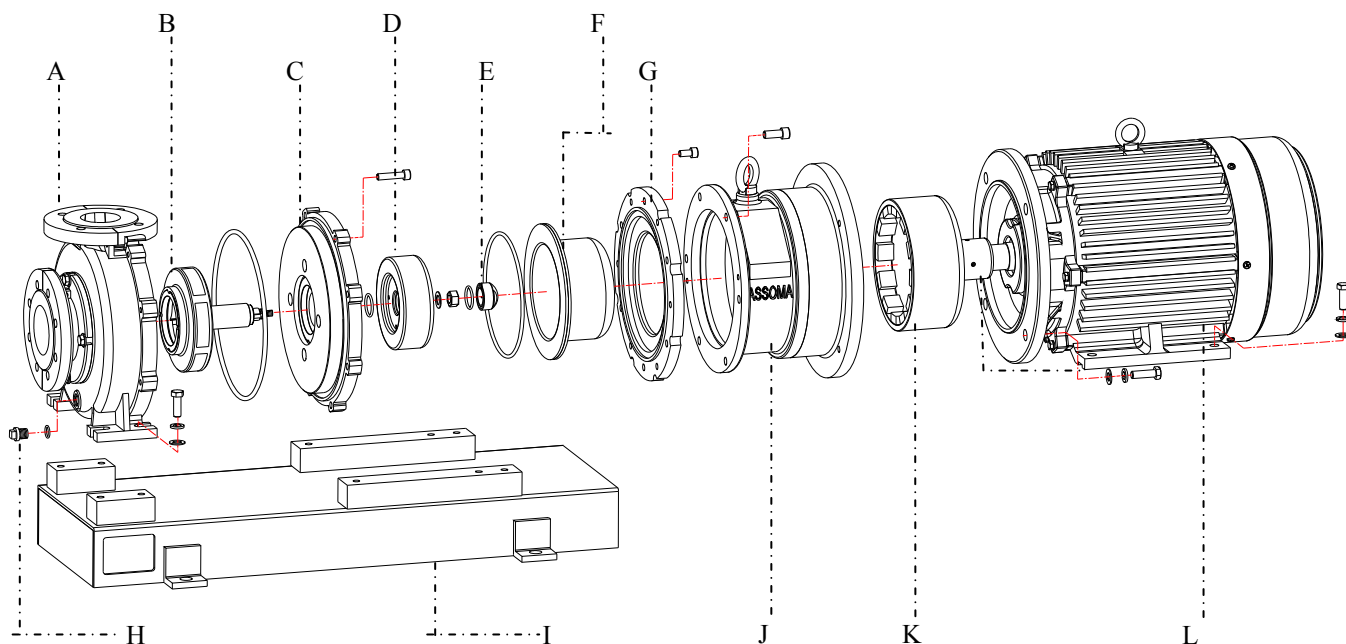

No.	Part	Material	
A	101	Pump casing	ETFE+CF
		Front thrust ring	SSiC/CERAMIC
	155.01	Casing armour	FCD
	155.02	Inlet armour	FCD
B	230	Impeller	ETFE+CF
		Front wear ring	SSiC/CARBON
		Rear wear ring	SSiC/CARBON
	211	Shaft	SUS316
C	523	Shaft sleeve	SSiC/CERAMIC
	343	Bearing frame	FC- ETFE+CF
D		Rear thrust ring	SSiC/CERAMIC
	310	Bearing	SSiC/CARBON
E	847	Magnet capsule	ETFE, Nd-Fe-B
F	920	Nut & washer	SUS316
	921	Shaft nut	ETFE
G	161.01	Rear casing with cover	ETFE+CF, CARBON FRP
H	161.02	Backup plate	FCD
I	912	Drain plug	ETFE+CF
J	890	Base	SUS304
K	181	Bracket	FC
	B22	Bracket adapter	FC
L	M01	Drive magnet	Nd-Fe-B
RG	EM	Motor	FC/Aluminum
		O-ring	VITON/EPDM

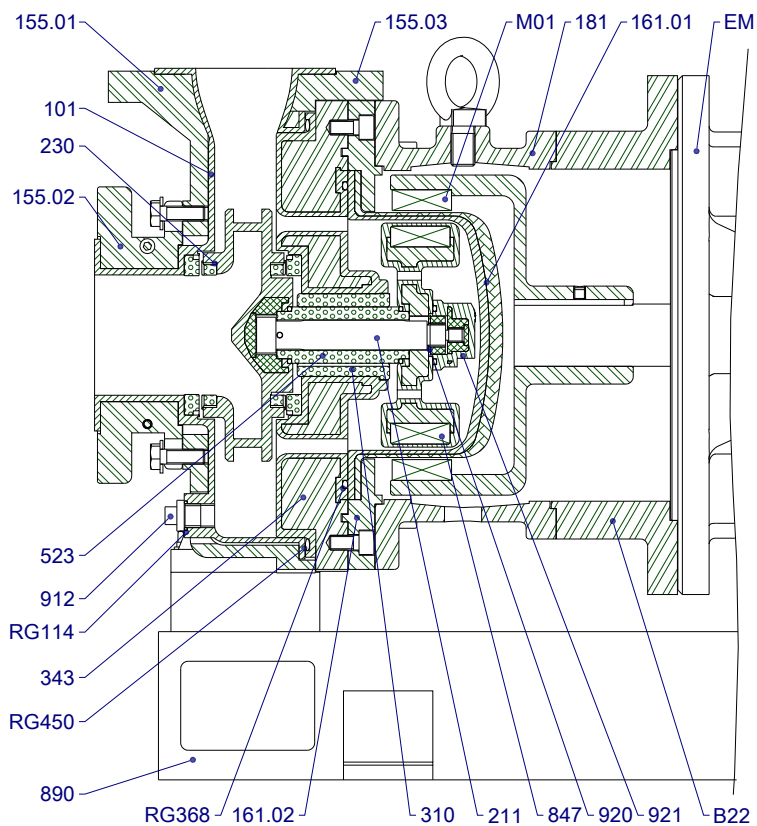



# **CRESTPUMPS** CHEMICAL PUMPING SOLUTIONS



[www.crestpumps.co.uk](http://www.crestpumps.co.uk)

T: 01425 627700

7 Queensway, New Milton, Hampshire,  
BH25 5NN