

☎ 01425 627700

🌐 [www.crestpumps.co.uk](http://www.crestpumps.co.uk)

✉ [info@crestpumps.co.uk](mailto:info@crestpumps.co.uk)

7 Queensway, New Milton, Hampshire, BH25 5NN



# CSS Range

**Vertical Sealless Thermoplastic  
Centrifugal Pumps**

## INSTALLATION, OPERATION AND MAINTENANCE MANUAL



## INDEX

### **1**    **GENERAL**

- 1:1    INTRODUCTION
- 1:2    GUARANTEE
- 1:3    CONTACT ADDRESS
- 1:4    NOISE
- 1:5    WARNINGS
- 1:6    SUPPLEMENTARY INSTRUCTIONS

### **2**    **DATA SHEET**

- 2:1    PARTS LIST
- 2:2    CROSS SECTIONAL ARRANGEMENT

### **3**    **DESCRIPTION**

### **4**    **INSTALLATION OF THE PUMP**

- 4:1    RECEIVING THE PUMP
- 4:2    TEMPORARY STORAGE
- 4:3    WIRING
- 4:4    INSTALLATION
- 4:5    MAXIMUM IMMERSION DEPTH
- 4:6    EXTENDED SUCTION PIPEWORK

### **5**    **OPERATION**

- 5:1    PRE-START CHECKS
- 5:2    STARTING
- 5:3    OPERATING CHECKS
- 5:4    SHUTDOWN

### **6**    **MAINTENANCE**

- 6:1    PREVENTATIVE MAINTENANCE
- 6:2    DISMANTLING INSTRUCTIONS
- 6:3    REPLACEMENT PARTS
- 6:4    PUMP RETURNS

## **1. GENERAL**

### **1.1 INTRODUCTION**

This manual is supplied to acquaint you with the easiest and most practical way to **INSTALL, OPERATE** and **MAINTAIN** this pump.

We suggest that all personnel responsible for this pump read this manual carefully and keep it handy for future reference. Additional information may be obtained direct from **CREST PUMPS LIMITED**.

Equipment can not operate well without proper care. To keep this unit at top efficiency, correct procedures for installing and maintaining must be followed. The **CREST PUMPS LIMITED** organisation can give helpful advice when installing this unit so that maximum machine life can be attained with the minimum downtime.

NOTE: The description and instructions in this book include the standard design of the equipment and common deviations, when possible. This manual does not cover all design details and variation nor does it provide for every possible contingency which may be encountered. When information cannot be found in this book contact **CREST PUMPS LIMITED** direct.

### **1.2 GUARANTEE**

All pumps are tested prior to despatch so that a trouble free operation of the pump is warranted.

The resistance of material can be guaranteed only if the specific operating conditions were known by **CREST PUMPS LIMITED** before commencement of the order.

The guarantee period is specified in our General Terms and Conditions of Sale.

### **1.3 CONTACT ADDRESS**

Crest Pumps Limited  
7 Queensway  
Stem Lane Ind Estate  
New Milton  
Hampshire  
BH25 5NN

Telephone:- 01425 627700 Fax:- 01425 627711  
Email:- info@crestpumps.co.uk

### **1.4 NOISE**

Depending upon the motor size fitted to this pump, the likely noise level can be found in the chart below. Please note that at certain installations and operation points on the pump curve, the noise level 70dB can be exceeded. Hearing protecting devices should be used in case of long exposure to noise.

Motor Power (kW)	Noise level at 1m dB(A)
0.55	58
0.75	58
1.1	61

1.5	61
2.2	66
3	66
4	69
5.5	69
7.5	70
9.2	70
11	70
15	70
18.5	72
22	72
30	72
37	76
45	76
55	77

## 1.5 WARNINGS AGAINST MISUSE

Safety instructions given in this Manual non-compliance with which would affect safety are identified by the following symbol :-



or where electrical safety is involved, with :-



Safety instructions which shall be considered for reasons of safe operation of the pump or pump unit and /or protection of the pump or pump unit itself are marked by the sign:-

**ATTENTION**

## 1.6 SUPPLEMENTARY INSTRUCTIONS

Supplementary components such as the motor for example, have to be used in accordance with the relevant instructions supplied with the pump's documents.

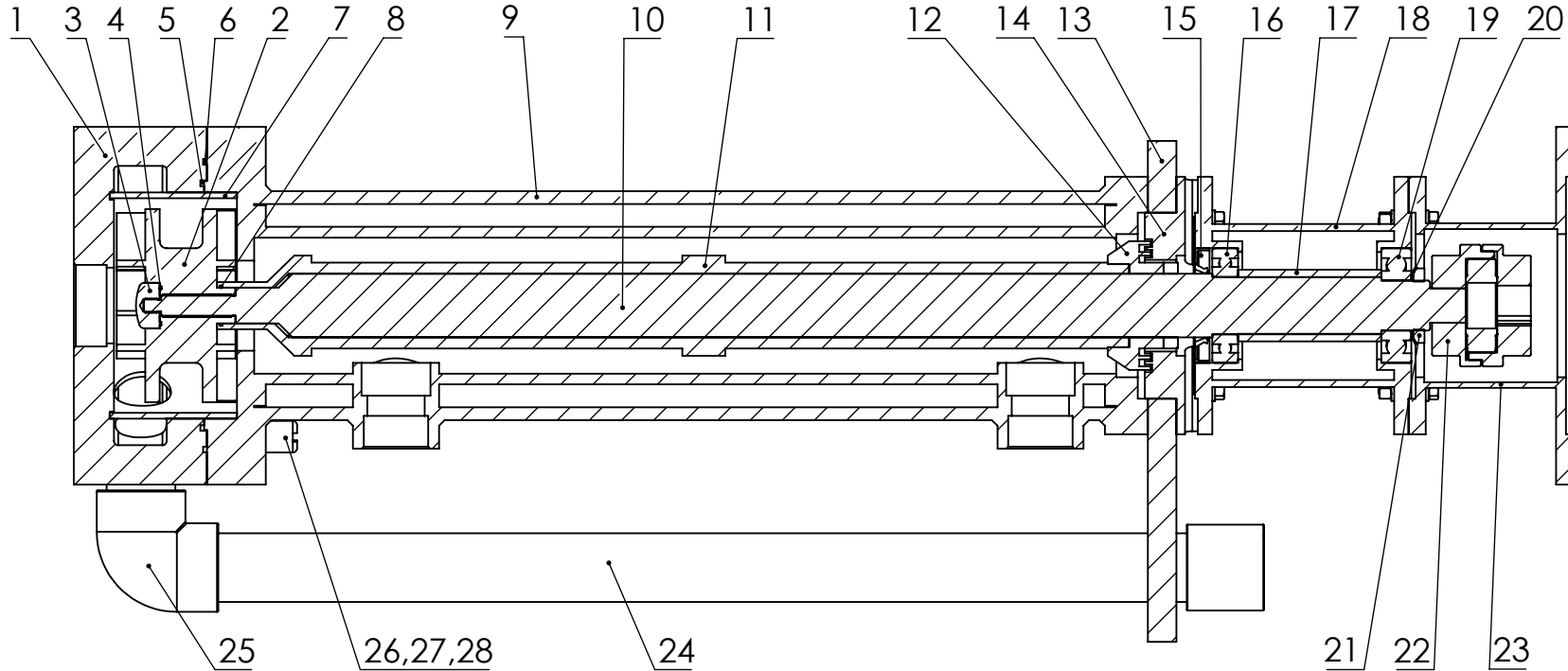

- 1. LOWER BODY
- 2. IMPELLER
- 3. LOCKNUT
- 4. O RING
- 5. O RING
- 6. O RING
- 7. DIFFUSER
- 8. O RING
- 9. UPPER BODY
- 10. SHAFT
- 11. SHAFT SLEEVE
- 12. LABYRINTH
- 13. MOUNTING PLATE
- 14. ADAPTOR
- 15. LIP SEAL
- 16. BEARING
- 17. SPACER
- 18. BEARING HOUSING
- 19. BEARING
- 20. WASHER
- 21. NUT
- 22. COUPLING
- 23. COUPLING HOUSING
- 24. DISCHARGE PIPE
- 25. ELBOW
- 26. STUD
- 27. O RING
- 28. ENCAPSULATED NUT

ALL UNTOLERANCED DIMENSIONS TO BE WITHIN +/- .25mm

	DRAWN BY: <b>J.HOBBY</b>	REVISION 1	REVISION 2	TITLE: <b>CSS RANGE</b>	ITEM	DESCRIPTION	MATERIAL	PART NUMBER	DRG NO:
	DATE: <b>08/02/2022</b>								<b>7322</b>
	CHECKED BY:	REVISION 3	REVISION 4	CUTTING LIST:					

### 3 **DESCRIPTION**

Pumps of the CSS series are vertical, immersible, single stage pumps designed to handle corrosive liquids and built to the highest possible standards of design, workmanship and materials.

The materials of construction have been selected for the temperature and liquid specified in your order. Before the pump is operated with other liquids or at other temperatures, it is essential that the manufacturer be consulted.

Each pump is tailored to the customers exact requirements in terms of generated head at the specific capacity and both the mechanical and hydraulic performance of the pump is checked before despatch.

**ATTENTION**

**This pump must not be run against a closed head**

**ATTENTION**



As per BS EN 13463-1:2009, item 6.7.5 c., for Atex Zone 1 Exd and Zone 2 Exn installations, the surface area of non-conductive parts has been minimised as best possible. But due to the corrosive nature of the liquid pumped and the requirement for this corrosion resistant material to be used, it is not possible to totally eliminate the danger of ignition by electrostatic discharges. This pump must be earthed at the earthing boss.

## 4. INSTALLATION OF THE PUMP

### 4:1 RECEIVING THE PUMP

1. UNLOAD AND HANDLE WITH CARE.
2. CHECK FOR SHORTAGES AND DAMAGE IMMEDIATELY AS YOU TAKE POSSESSION OF THE PUMP.

Prompt reporting of discrepancies to the carrier's agent, with notations made on the Bill of Freight, will expedite satisfactory remedial action by either the carrier or the manufacturer.

### 4:2 TEMPORARY STORAGE

If the pump is not required for immediate installation and operation, store in a clean, dry place at a consistent ambient temperature and ensure that all openings are protected to prevent the ingress of foreign matter. Rotate the pump shaft assembly on a weekly basis to prevent damage to the seals.

Storage requirements vary depending on the length of storage and climate conditions. For storage periods longer than three months or advice on storage temperature, please contact **CREST PUMPS LIMITED**



### 4:3 WIRING

The electrical installation must be carried out by a competent person. All relevant practices and regulations should be adhered to. The motor wiring should be carried out to the manufacturers instructions which can usually be found in the motor terminal box or supplied with the motor. A wiring diagram can be found in the terminal box or on the motor nameplate. Thermal overload protection should be used but is not supplied with the motor. Ensure that rotation is in the correct direction as shown by arrows on either the motor or pump. (See 5.1) If required, earthing bosses are supplied and should be used.



### 4.4 INSTALLATION

The CSS Range of Pumps must be mounted vertically, but may be installed either internally or externally. When the pump is mounted externally it is important to plumb the drain hole back into the tank. See fig. 1 & 2

**N.b.** Fitting of a non-return valve at the discharge port is recommended to prevent liquid surging back into the pump and bearing housing as the pump is switched off. See fig. 3

<b>ATTENTION</b>
------------------

### 4.5 MAXIMUM IMMERSION DEPTH

Ensure that the pump is installed so that the liquid level will not rise above the underside of the mounting plate.

<b>ATTENTION</b>
------------------

#### **4.6 EXTENDED SUCTION PIPEWORK**

The Crest CSS range pipework is supplied in standard lengths, however, it is possible for pumps to empty deeper tanks and sumps. Inlet extensions may be added up to 2.5 metres long with the effect that the unit will continue pumping until the liquid level drops below the inlet extension and air is drawn in.

Should the installation require the pump to come into operation before the liquid level rises back above the pump casing, then a foot valve will need to be fitted to the inlet extension. This will prevent liquid draining out of the pump body and the pump will be maintained in a primed condition. See fig. 3

When a foot valve is installed as in the previous example, it is necessary to install a check valve at the discharge port. This will prevent the liquid in the discharge line from flowing back into the pump and rising up the inside of the pump body when the pump is halted. See fig. 3

**Figure 1.  
Internal Installation**

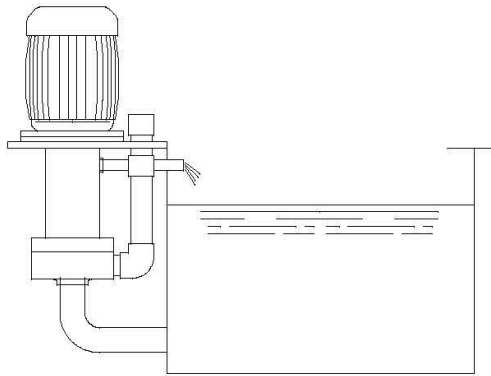
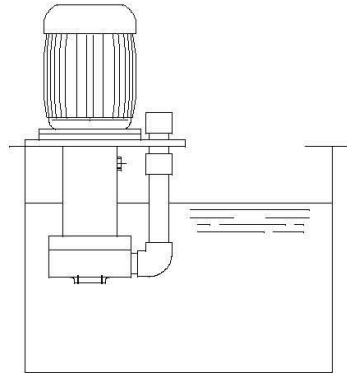

**Figure 2.  
Internal Installation  
(Plumbed in drain hole)**

**Figure 3.  
Extended pipework**

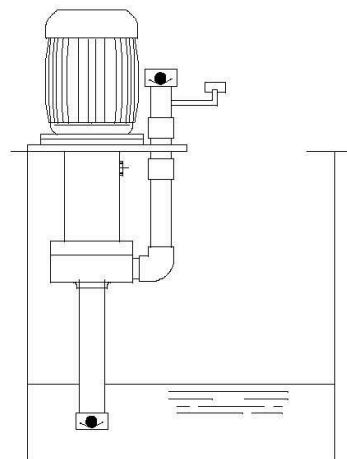

## 5. OPERATION

### 5.1 PRE-START CHECKS

Before initial start up of the pump, make the following inspection:

- (a) Check all connections to motor and starting device for correct installation. Also voltage, phase and frequency are as motor nameplate for the circuit being used.
- (b) Turn rotating element by hand to ensure it rotates freely.
- (c) Check rotation by giving the motor a 2 second burst maximum. If incorrect, change wiring to give correct rotation.



**Pump must operate in the direction indicated by the arrows on motor and pump adaptor. Serious damage can result if the pump is operated with the incorrect rotation. Always check rotation each time the motor or starter have been disconnected.**



**Pump must be completely filled with liquid before starting. Never allow pump to run dry in the hope it will prime itself. Serious damage to the pump will take place if this is allowed to happen.**

- (d) Check discharge piping and any other connections (eg. pressure gauge, temperature and flow control instruments) for correct operation.

### 5:2 STARTING

- (a) Close any drain valves in discharge line.
- (b) Open fully all valves in suction line.
- (c) Prime Pump. If the pump does not prime properly or loses prime during start up, it should be shut down and condition corrected before the procedure is repeated.



**Repeated trial start ups can overheat the motor. Starting currents are several time full load current - heating varies as the SQUARE of the current. Allow winding time to cool between starts.**

- (d) For pumps moving high temperature liquids it is advisable to warm the pump prior to starting to avoid thermal shock on the materials used in the construction of the pump head eg., impeller, casing and backplate.

- (e) Start pump prime mover.



**The discharge line valve should always be set to achieve the pump's minimum flow requirement usually achieved with a cracked discharge valve open slightly when pump is started. The excessive current**

**required by the motor to start under full load will, in time, cause motor trouble.**

- (f) When pump is operating at full speed open the discharge valve slowly.

### 5:3 OPERATING CHECKS

- (a) Check pump and piping leaks.
- (b) Check and record pressure readings for future reference.
- (c) Check and record voltage, amperage per phase and kW.
- (d) Check temperature at various points on the pump to make sure that the pump is not overheating.



**Make all pump output adjustments with discharge valve. DO NOT throttle suction line to adjust pump output.**

- (e) When the pump is operated with a Variable Speed Drive, the operating speed range must be no lower than 50% of the rated speed and no higher than the rated speed.

### 5:4 SHUTDOWN

- (a) When stopping the pump always close the discharge valve first. Pump should never run dry for any length of time with this valve shut or the suction valve closed or both closed, due to the damage of overheating and causing a meltdown of plastic parts of the pump.
- (b) In severe climate conditions the pump should be protected from freezing conditions when shut down by one of the following methods:
  - i. Drain pump and remove all liquid from casing if this liquid is liable to freeze solid.
  - ii. Keep fluid moving in the pump and pipework to insulate to prevent freezing.
  - iii. Heat pump and pipework to prevent freezing.



**If heat is used to keep pump from freezing do not let temperature rise above 60 degrees centigrade unless permission to do so has been obtained from CREST PUMPS LIMITED.**

#### **ATTENTION**

In freezing conditions it is important to keep pipework from freezing. A blockage in the pipe can result in overheating the pump.

## 6 MAINTENANCE

### 6:1 PREVENTIVE MAINTENANCE

A pump properly installed and operated will require a minimum of maintenance. For the best overall performance be sure to adhere to the instructions in this manual.

Operating conditions vary so widely that to recommend one schedule of preventative maintenance for all duties covered by our pumps is not possible. Keep a permanent record of the periodic inspection and maintenance performed on the pump.

The recognition of maintenance procedure will keep the pump in good working condition and prevent costly breakdowns.

One of the best rules to follow in proper maintenance is to keep a record of actual operation data and hours of operation. The length of this operation period will vary with different applications and can only be determined from experience. The next inspection can be scheduled based on the condition of the components at the first inspection. This system can be followed until a maximum period of operation is reached, which should be considered the operating schedule between inspections. A guide for performing periodic inspections on the pump follows:

<b>PERIOD</b>	<b>INSPECTION</b>
Monthly	Check bearing in motor and bearing pedestal when fitted for temperature and wear. A bearing that has become noisy is obviously showing signs of wear.
3 Monthly	Monthly checks plus check for leaks from pump and pipework and repair as required.
6 Monthly	Monthly and 3 monthly checks. Inspect operation of all valves and instrumentation for correct operation. Special attention to be paid to non-return and foot valves, if fitted, as poor operation of these valves can result in poor performance of the pump.
Yearly	All previous checks, also remove rotating element and inspect for damage and wear, ordering replacement parts if necessary. Remove any deposit or scaling with particular attention to the mechanical seal area.  Measure total dynamic suction and discharge head as a test of pipe connections. Record figures and compare them with the figures of the next test. This is important especially where the fluid being pumped tends to form a deposit on internal surfaces.

#### Recommended 2 Year Spares

Please refer to the Parts List (2:1) for the exact part numbers for your pump. It is recommended to the following parts are replaced every two years: all bearings, o-rings and oil seals.

## 6:2 DISMANTLING INSTRUCTIONS



- A. **Never attempt to dismantle the pump unit until it has been disconnected from the mains electricity supply.**
  - B. **Release the discharge pipework.**
  - C. **Ensure that the pump is thoroughly de-contaminated of the fluid it has been pumping.**
  - D. **Remove the pump to a safe and clean working area.**
1. Unscrew discharge pipework and withdraw.
  2. Remove lower body encapsulated nuts and O' rings.
  3. Remove the lower body taking care not to damage the sealing O' rings. The diffuser will be retained in the body.
  4. Remove the nuts, bolts and washers holding the motor adaptor.
  5. Separate the motor from the adaptor.
  6. Remove the impeller locknut (L/H thread) and O' ring.
  7. Remove the impeller from the shaft (R/H thread or square drive).
  8. Remove nuts and washers holding the upper body to the adaptor. Remove upper body.
  9. Remove shaft sleeve and labyrinth.
  10. Remove the mounting plate.
  11. Slacken the coupling grub screws and remove coupling halves and spider.
  12. Remove lock tab from nut. Remove nut (R/H thread).
  13. Press out shaft from bearing assembly from the motor end.
  14. Remove bearings from housing along with oil seal & spacer.
  15. Slacken grub screw from shaft collar. Slide off collar in either direction.

The pump is now in a totally dismantled state and parts should be replaced as required. We recommend that bearings and O-rings are renewed each time the pump is stripped down.

The pump may now be re-assembled in reverse order. If the diffuser is removed from the lower body the pin must be located in the hole when refitting to ensure correct alignment.

## 6:3 REPLACEMENT PARTS

Pumps are designed and built with all wearing parts being replaceable. A recommended inventory of spare parts is dependent upon installation and the importance of continued operation.

Parts should be ordered as far in advance as possible since circumstances beyond the control of the Company may reduce existing stock. Not all parts are stocked as some must be manufactured for each order.

When ordering spare parts always include the following information:

**Pump Serial Number and/or Pump Type**  
**Part number obtained from drawing/parts list**  
**Name of part and quantity of part required**  
**Material desired (if different from original material)**  
**Full Company details including delivery/invoice address**  
**Order Number.**

**NOTE** Parts will be supplied in the original materials unless specified as a material change. All material substitutions should be discussed with **CREST PUMPS LIMITED.**

T: 01425 627700

W: [www.crestpumps.co.uk](http://www.crestpumps.co.uk)

A: 7 Queensway, New Milton, Hampshire, BH25 5NN



## Pump Return Form

All pumps returned to us must be accompanied with this completed form stating what product the pump has been handling and that the pump has been thoroughly cleaned. This documentation should be securely attached to the returned item and be clearly visible. If not, the shipment shall be rejected and returned to the sender

Date Sent:		Company Name:	
Contact Name:		Tel No:	
Email Address			
Pump Type:		Serial Number	
Liquid(s) this pump has been handling (please supply MSDS where possible)			
Are they a health hazard?	Yes / No	Do they give off dangerous products after thermal decomposition?	Yes / No
If yes to either of the above, please provide further information:			
Reason for Return:			

**Legally Valid Declaration:** I, as the undersigned, have the skills to judge and confirm this pump has been safely cleaned and drained before despatch. If not adequately cleaned, we accept the pump maybe rejected and/or we will be liable for the chemical cleaning and waste disposal costs. We commit to exempting Crest Pumps Ltd from any claim for damages by third parties that have occurred due to incomplete or erroneous information. We are aware that, independently from this statement, we are directly accountable to third parties, particularly with respect to Crest Pumps Ltd personnel responsible for handling or repairing the product.

Name of authorised Person (please print): \_\_\_\_\_ Date \_\_\_\_\_

Signature: \_\_\_\_\_

Please return to:

Crest Pumps Ltd  
7 Queensway  
New Milton  
Hampshire  
BH25 5NN

Please note that if we do not receive a response within 60 days of our inspection report / quote, we reserve the right to scrap the pump without further notice.

# **CRESTPUMPS** CHEMICAL PUMPING SOLUTIONS



[www.crestpumps.co.uk](http://www.crestpumps.co.uk)

T: 01425 627700

7 Queensway, New Milton, Hampshire,  
BH25 5NN