

+44 (0) 1425 627700

www.crestpumps.co.uk

info@crestpumps.co.uk

7 Queensway, New Milton, Hampshire, BH25 5NN

CRESTPUMPS
CHEMICAL PUMPING SOLUTIONS

EOV Range

Corrosion resistant, mechanically sealed centrifugal pumps

Installation, Operation & Maintenance Manual



INDEX

1 **GENERAL**

- 1:1 INTRODUCTION
- 1:2 GUARANTEE
- 1:3 CONTACT ADDRESS
- 1:4 NOISE
- 1:5 WARNINGS
- 1:6 SUPPLEMENTARY INSTRUCTIONS

2 **DATA SHEET**

- 2:1 PARTS LIST & CROSS SECTIONAL
 ARRANGEMENT

3 **DESCRIPTION**

4 **INSTALLATION OF THE PUMP**

- 4:1 RECEIVING THE PUMP
- 4:2 LOCATION
- 4:3 FOUNDATION
- 4:4 PIPING
- 4:5 MECHANICAL SEAL
- 4:6 ELECTRICAL

5 **OPERATION**

- 5:1 PRE-START CHECKS
- 5:2 STARTING
- 5:3 OPERATING CHECKS
- 5:4 SHUTDOWN

6 **TROUBLE SHOOTING**

7 **MAINTENANCE**

- 7:1 PREVENTATIVE MAINTENANCE
- 7:2 LUBRICATION
- 7:3 DISMANTLING INSTRUCTIONS
- 7:4 ASSEMBLY INSTRUCTIONS
- 7:5 REPLACEMENT PARTS
- 7:6 PUMP RETURNS

1. GENERAL

1.1 INTRODUCTION

This manual is supplied to acquaint you with the easiest and most practical way to **INSTALL, OPERATE** and **MAINTAIN** this pump.

We suggest that all personnel responsible for this pump read this manual carefully and keep it handy for future reference. Additional information may be obtained direct from **CREST PUMPS LIMITED**.

Equipment can not operate well without proper care. To keep this unit at top efficiency, correct procedures for installing and maintaining must be followed. The **CREST PUMPS LIMITED** organisation can give helpful advice when installing this unit so that maximum machine life can be attained with the minimum downtime.

NOTE: The description and instructions in this book include the standard design of the equipment and common deviations, when possible. This manual does not cover all design details and variation nor does it provide for every possible contingency which may be encountered. When information cannot be found in this book contact **CREST PUMPS LIMITED** direct.

1.2 GUARANTEE

All pumps are tested prior to despatch so that a trouble free operation of the pump is warranted.

The resistance of material can be guaranteed only if the specific operating conditions were known by **CREST PUMPS LIMITED** before commencement of the order.

The guarantee period is specified in our General Terms and Conditions of Sale.

1.3 CONTACT ADDRESS

Crest Pumps Limited
7 Queensway
Stem Lane Ind Estate
New Milton
Hampshire
BH25 5NN

Telephone:- 01425 627700 Fax:- 01425 627711
Email:- info@crestpumps.co.uk

1.4 NOISE

Depending upon the motor size fitted to this pump, the likely noise level can be found in the chart below. Please note that at certain installations and operation points on the pump curve, the noise level 70dB can be exceeded. Hearing protecting devices should be used in case of long exposure to noise.

Motor Power (kW)	Noise level at 1m dB(A)
0.55	58
0.75	58
1.1	61

1.5	61
2.2	66
3	66
4	69
5.5	69
7.5	70
9.2	70
11	70
15	70
18.5	72
22	72
30	72
37	76
45	76
55	77

1.5 WARNINGS AGAINST MISUSE

Safety instructions given in this Manual non-compliance with which would affect safety are identified by the following symbol :-



or where electrical safety is involved, with :-



Safety instructions which shall be considered for reasons of safe operation of the pump or pump unit and /or protection of the pump or pump unit itself are marked by the sign:-

ATTENTION

1.6 SUPPLEMENTARY INSTRUCTIONS

Supplementary components such as the motor for example, have to be used in accordance with the relevant instructions supplied with the pump's documents.

IF IN DOUBT ASK!

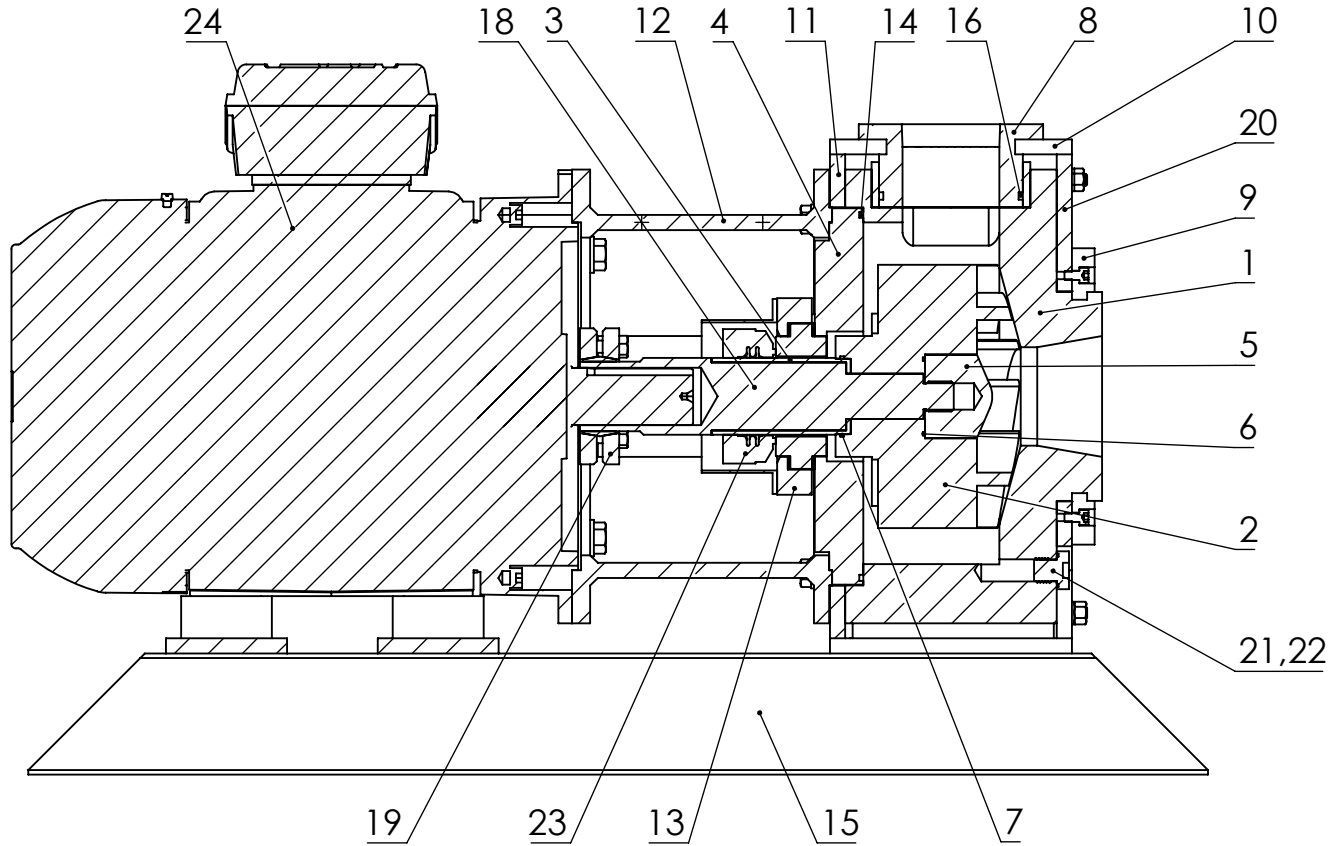

1. CASING
2. IMPELLER
3. IMPELLER SLEEVE
4. BACKPLATE
5. LOCKNUT
6. O RING
7. O RING
8. DISCHARGE BRANCH
9. SUCTION FLANGE
10. DISCHARGE FLANGE
11. BACK COVER PLATE
12. ADAPTOR
13. SEAL HOUSING
14. O RING
15. BASEPLATE
16. O RING
17. O RING
18. SHAFT
19. COUPLING
20. FRONT COVER PLATE
21. PLUG
22. O RING
23. MECHANICAL SEAL
24. MOTOR

ALL UNTOLERANCED DIMENSIONS TO BE WITHIN +/- .25mm

 <p>CRESTPUMPS CHEMICAL PUMPING SOLUTIONS</p>	DRAWN BY: J.HOBBY	REVISION 1 	REVISION 2 	TITLE: EOV RANGE MSC SEAL	ITEM 	DESCRIPTION 	MATERIAL 	PART NUMBER 	DRG NO:
	DATE: 02/02/2022	REVISION 3 	REVISION 4 	CUTTING LIST: 					
	CHECKED BY: 								

IF IN DOUBT ASK!

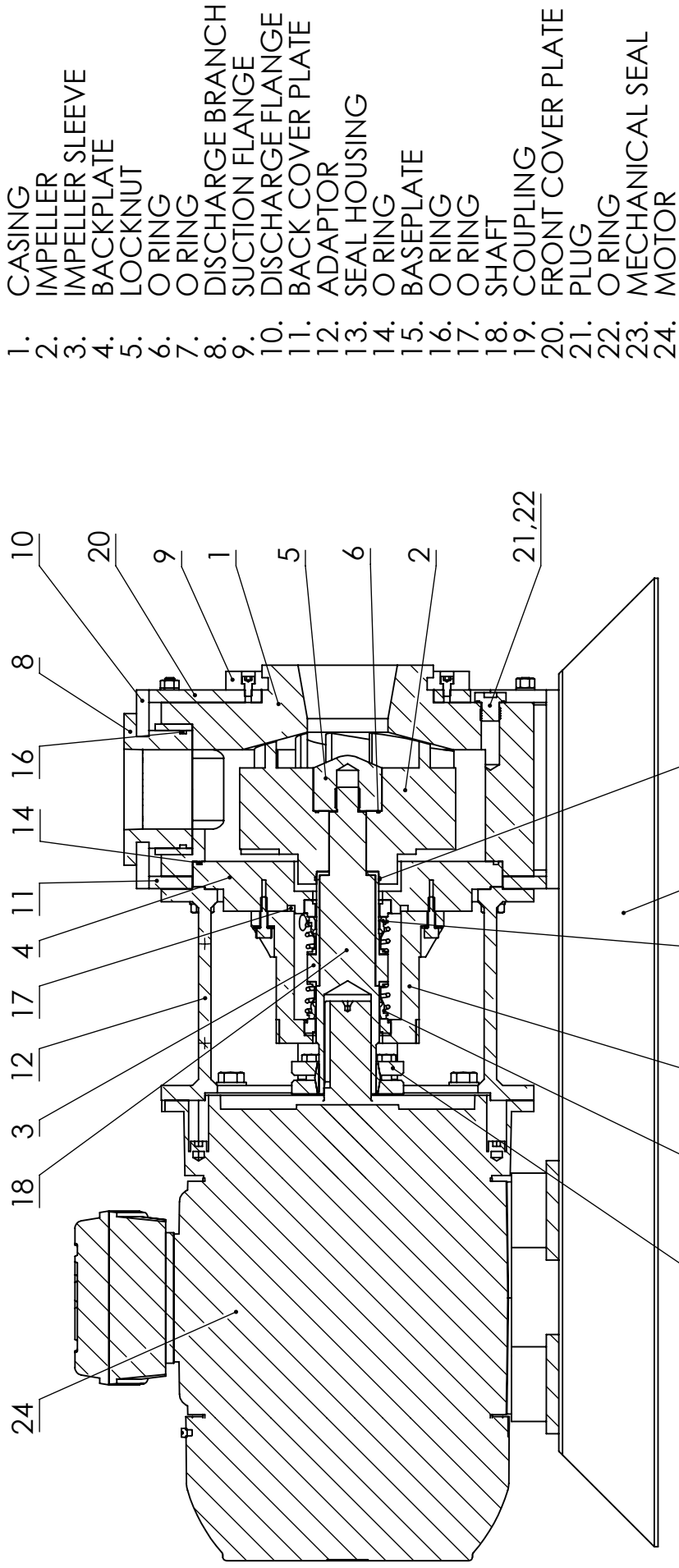

- 1. CASING
- 2. IMPELLER SLEEVE
- 3. BACKPLATE
- 4. LOCKNUT
- 5. O RING
- 6. O RING
- 7. DISCHARGE BRANCH
- 8. SUCTION FLANGE
- 9. DISCHARGE FLANGE
- 10. BACK COVER PLATE
- 11. ADAPTOR
- 12. SEAL HOUSING
- 13. O RING
- 14. BASEPLATE
- 15. O RING
- 16. O RING
- 17. SHAFT
- 18. COUPLING
- 19. FRONT COVER PLATE
- 20. PLUG
- 21. O RING
- 22. MECHANICAL SEAL
- 23. MOTOR
- 24. MOTOR

ALL UNTOLERANCED DIMENSIONS TO BE WITHIN +/- .25mm

CRESTPUMPS
 CHEMICAL PUMPING SOLUTIONS

DRAWN BY: J.HOBBY
 DATE: 02/02/2022
 CHECKED BY:

REVISION 1	REVISION 2	TITLE:
		EOV RANGE
		DOUBLE MSH SEAL
REVISION 3	REVISION 4	CUTTING LIST:

ITEM	DESCRIPTION	MATERIAL	PART NUMBER	DRG NO:
				7317

3 **DESCRIPTION**

Pumps of the EOVS series are horizontal end suction, single stage pumps designed to handle corrosive liquids and built to the highest possible standards of design, workmanship and materials.

The pumps are available for temperatures up to 120 degrees centigrade dependent on materials used, higher temperatures are available on a limited range of pumps.

The materials of construction have been selected for the temperature and liquid specified in your order. Before the pump is operated with other liquids or at other temperatures, it is essential that the manufacturer be consulted.

Each pump is tailored to the customers exact requirements in terms of generated head at the specific capacity and both the mechanical and hydraulic performance of the pump is checked before despatch.

Shaft rotation is clockwise looking from drive end.

The body of the pump consists of an integral suction and discharge volute casing, which houses the impeller. The discharge is normally supplied in the vertical position but alternative positions are available on request. The method of shaft sealing is by mechanical seal which has been selected to suit the application.

The pumps are of a rear pull out design so that the working parts of the pump can be removed leaving the casing and pipework undisturbed.

ATTENTION

This pump must not be run dry

(Dry run protection monitors are available from Crest Pumps Ltd if required. Please contact us for more information)

This pump must not be run against a closed head

ATTENTION



For Atex Zone 1 Exd and Zone 2 Exn installations, the EOVS series will be manufactured with a stainless steel shroud to cover the plastic casing and backplate. As per BS EN 13463-1:2009, item 6.7.5 c., the surface area of non-conductive parts has been minimised. The pump must also be earthed at the earthing boss on the shroud.

4. INSTALLATION OF THE PUMP

4:1 RECEIVING THE PUMP

- (a) Check pump for shortages and damage immediately after arrival. Prompt reporting to the carriers agent, with notations made on the bill of freight, will expedite satisfactory adjustment by the carrier.
- (b) Unload and handle with care. On the larger models fitted with a baseplate, these can be unloaded with a fork lift truck under the baseplate or using a hoist and sling round the motor and adaptor part of the pump. On all pumps it is important that no strain is put on the plastic parts of the pump especially the suction and discharge branches if fitted.
- (c) **TEMPORARY STORAGE**
If the pump is not to be installed and operated soon after arrival, store in a clean dry place having a slow to moderate change in ambient temperature and ensure all openings are protected to stop the ingress of foreign matter. Rotate pump shaft assembly weekly to stop damage to mechanical seal.

Storage requirements vary depending on the length of storage and the climate conditions. For storage periods longer than 3 months or special conditions consult manufacturer.

4:2 LOCATION

- (a) Install pump as near the suction supply as possible, with the shortest most direct suction pipe practical. The total dynamic suction lift (static lift plus friction losses in suction line) should not exceed the limits for which the pump was sold on self priming models.
- (b) **THE PUMP MUST BE PRIMED BEFORE STARTING.** (See 5:1).
Whenever possible locate the pump below storage level of liquid to facilitate priming and assure a steady flow of liquid. This condition provides a positive suction head on the pump. It is possible to obtain this condition by pressurising the suction vessel.
- (c) When installing the pump consider the location of it in relation to the system, to ensure that sufficient Net Positive Suction head (NPSH) at the pump suction is provided. Available NPSH must always equal or exceed the required NPSH of the pump.
- (d) Place pump with sufficient accessibility for inspection and maintenance. A clear space with ample head room should be allowed on the larger pumps to allow for an overhead crane or hoist to lift unit. **NOTE** Allow sufficient space to dismantle pump without disturbing the pump outlet or discharge pipework.
- (e) Select a dry place above floor level wherever possible. Take care to prevent the pump freezing during cold weather when not in operation. Should the possibility of freezing exist during a shut-down period the pump should be completely drained and all passages and pockets where liquid might collect should be blown out with compressed air.
- (f) Make sure the power source is suitable for the electric motor provided. All characteristics must agree with motor data plate also the correct motor overload protection must be installed.

- (g) The pump rotation is **CLOCKWISE** viewed from the drive end. (See 5:1).

4:3 FOUNDATION

- (a) The pump foundation and type of installation should be designed so that vibration is kept to a minimum both during operation and when pump is at rest, otherwise pump life will be reduced.
- (b) The proposed foundation for the pump set must have a reasonably flat and level surface with pockets of generous size to accept the foundation bolts.
- (c) A drain must be provided for pumps fitted with water flush seals. If this is not practical, an enclosed pressure system with pump and tank should be installed. (See 4:5).
- (d) The pump set must be positioned so that it is in line with any existing pipework. A spirit level should be placed on the suction and discharge flanges. When fitted, check level both axially and transversely. With horizontal branches the flange must be vertical. Pumps without branches and flanges should have a short length of pipe screwed into the suction and discharge and levels taken from these.
- (e) Loosely fasten the foundation bolts in the baseplate or the motor for pumps without baseplate and lower pumpset onto foundation. Insert under the baseplate adjacent to the foundation bolts a 12mm thick x 50mm wide x 100mm long packing block. For motors, only, these blocks will have to be made to suit motor feet. Place shim on the packers to level up the pumpset. When level is correct, grout in foundation bolts, ensuring that they hang freely and vertically in the pockets. Allow concrete to harden.
- (f) Tighten bolts down uniformly and re-check level of pumpset. If necessary place further shims on the packers until horizontal alignment of pumpset is achieved.
- (g) Following manufacture, all openings of the pump are sealed and these should **NOT** be removed until pipework is ready to be attached. If it is necessary to remove these covers for levelling the pumpset, they should be replaced immediately after the levelling procedure has taken place. The pump should also be protected if further sitework nearby is necessary.

4.4 PIPING

Suction and Discharge Pipework

Pipe diameters will have already been determined at the planning stage and many factors unknown to the pump manufacturer will have to be taken into account.

A minimum flowpipe may be required if the pump is operated at very low flow rates. This pipe is not supplied by the pump manufacturer, so must be provided by the user.

In the partial-load range (when operating the pump near zero flow) almost the total pump power is imparted to the flow as thermal energy. If this flow is less than a certain minimum, heating will occur and continue until the liquid boils, causing severe damage to the impeller and casing leading to eventual breakdown of the pump.

To avoid this it is necessary to install a leak-off device immediately down stream of the pump which must be guaranteed to pass the minimum flow even when the discharge valve is closed.

This minimum flow requirement can be met by installing a continuous by-pass line up-stream of the discharge valve. This line is led back to the supply tank and must contain a throttling device to control the flow and reduce the pressure.

If a shut-off device has to be installed in the minimum flow line for maintenance purposes it must be locked open before start up.

If several pumps are installed to operate in parallel and the minimum flow pipework connects into a common header, it is necessary to install a non-return valve in each minimum flow pipe.

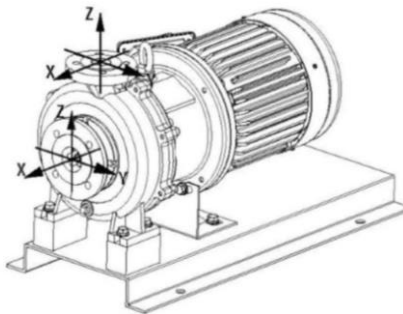

SUCTION							
Force (N)				Moment (N-m)			
F _x	F _y	F _z	ΣF	M _x	M _y	M _z	ΣM
1200	900	750	1350	450	400	400	675

DISCHARGE							
Force (N)				Moment (N-m)			
F _x	F _y	F _z	ΣF	M _x	M _y	M _z	ΣM
600	675	750	1125	450	400	450	600

Drip Tray

Where fitted, a connection to the drip tray will extend through the guard ending with a ¼" BSP M connection. It is the users responsibility to pipe this to a suitable drain. Please note this a supplementary safety feature which will only come in to use the event of seal failure and is designed to protect the adaptor from corrosion.

4.5 MECHANICAL SEAL

General

Mechanical seals are used on Crest EOV range of pumps because of their unique sealing qualities and long serviceability. The seal arrangement for each pump is specially selected by our engineers for compatibility with the fluid being pumped - as specified in the customers order.

Water Flush Seals

The flushing fluid pressure must at all times exceed the pump delivery pressure by 1 to 1.5 bar. However, it must not exceed the pressure limit of the seal on the atmospheric side. The pressure within the seal housing is normally controlled by fitting a valve on the outlet side of the seal housing or in the outlet pipework - the flow being restricted to give a back pressure within the seal housing. The outlet flow of flushing fluid should be about **0.5 litre per minute**. Suitable protection should be taken against the risk of frost damage. Do not start the pump until the correct pressure has been achieved.

Where the seal is flushed by a vessel, the user must fill this with lubricant fluid that is compatible with the classified zone, the pumped liquid, the material of the pump and the seal. The user must also arrange the connections with the seal seat. The vessel must be equipped with the necessary controls to guarantee the liquid presence and the pressure required. The surface temperature of the vessel is subject to the application conditions and external temperature – check that this does not exceed the values fixed by the zone's classification.

When the pump has been purchased with the Crest SS25 sealing system, please also refer to the separate SS25 Installation and Operation Manual.

Assembly

As a general rule the liquid velocity should not exceed 2 M per second in the suction pipework and 3 M per second in the discharge pipework.

It is also a good engineering practice for the suction pipework to be a least one pipe size larger than the nominal bore of the suction flange. A few useful hints are given below which should be observed when the pipework is installed.

The pipework must be supported in an adequate manner to ensure that no bending movements or stresses caused by the weight of the pipework or thermal expansion are transmitted to the pump flanges (install an expansion piece). The pipework flanges must be parallel to the pump flanges.

On flooded suction applications, the horizontal section of the pipework should descend towards the pump and on suction lift applications they should steadily rise towards the pump to prevent air locking.

The pieces should be designed and constructed so as not to obstruct the free flow of the liquid. The transition from small to large pipe diameters must be gradual. As a general guide, the length of a concentric taper piece must be 5 - 7 times the difference in pipe diameters. if the taper piece is in the horizontal position it must be of the eccentric type to prevent a vapour pocket forming.

Where flanged joints are used, ensure that the gasket is correctly centered so that the bore of the pipe is not restricted.

Sudden reductions in pipe cross section area (e.g. reducing bushes) and sharp bends should be avoided especially in the suction pipework, as these greatly increase

the frictional resistance within the pipework. A high frictional resistance within the suction branch can, in severe cases, lead to service problems.

Multi-pump installation should have separate suction pipes to each pump. Excepted are duty and stand-by pumps which may have common suction pipework since only one pump operates at any time.

Cleaning the Pipework

Before a pumpset is commissioned, all traces of foreign bodies and impurities must be carefully flushed out of the supply tank and pipework. Where pipework has been welded, all welding slag etc must be removed.

In order to prevent any of the above impurities entering the pump, it may be necessary to install a strainer in the suction pipework for a short period immediately following commissioning. A mesh size of 0.3 to 0.4 mm should be adequate. The total effective area of the filter must be at least four or five times the pipe cross sectional area.

If at any time a reduction in pump pressure is observed, then the strainer should be removed and cleaned. After a period of time when it is certain that no more impurities remain in the pipework, the suction strainer can be removed.

The inlet supply to the seal housing must be fed from a suitable source to give the required pressure. If mains water is used as the supply, an anti-syphon device must be fitted to stop any possible contamination

Other alternative methods of supply are an enclosed circuit pumped system or an enclosed pressure system with a pressure accumulator to supply the pressure required. For advice on the correct installation **CREST PUMPS LIMITED** should be contacted.

4.6 ELECTRICAL



The electrical installation must be carried out by a competent person. All relevant practices and regulations should be adhered to. The motor wiring should be carried out to manufacturers instructions which can usually be found in the motor terminal box or supplied with the motor. A wiring diagram can be found in the terminal box or on the motor nameplate. Thermal overload protection should be used but is not supplied with the motor. Ensure that rotation is in the correct direction as shown by arrows on either the motor or pump. (See 5.1) If required, earthing bosses are supplied and should be used.

5. OPERATION

5.1 PRE-START CHECKS

Before initial start up of the pump, make the following inspection:

- (a) Check the alignment between pump and motor on long coupled series pumps, in case base plate has been distorted on installation.
- (b) Check all connections to motor and starting device for correct installation. Also voltage, phase and frequency are as motor name plate for the circuit being used.

- (c) Check open impeller adjustment where possible. (See 7:4).
- (d) Pumps with flushing type seals - make sure installation is as 4:5 and flushing system is turned on.
- (e) Turn rotating element by hand to ensure it rotates freely.
- (f) **DO NOT PRIME PUMP BEFORE FIRST CHECKING** rotation by giving the motor a flick test (**1 second burst maximum**). If incorrect, change wiring to give correct rotation.



Pump must operate in the direction indicated by the arrows on motor and pump adaptor. Serious damage can result if the pump is operated with the incorrect rotation. Always check rotation each time the motor or starter have been disconnected.

- (g) Prime the pump fully with liquid.

Priming

If the pump is installed with a positive suction head it can be primed by opening the suction valve and allowing the liquid to enter the casing. Open the discharge line valve to allow air to vent out of the casing. If a non-return valve is fitted in the discharge line provision must be made for venting between the pump and non-return valve.

If the pump is installed with a suction lift, a priming chamber is fitted to the suction side of the pump. The suction pipework should be installed as 4:4 with an efficient foot valve or non-return valve in order to assist priming. The system must be filled with liquid before the pump is operated. This can be done by removing the filler plug in the top of the priming chamber and filling through this hole. The plug must be replaced and made air tight before starting the pump.

The system should need no further re-priming unless the system is drained or the suction pipe uncovered allowing air into the system and losing the prime.

It is essential that the suction pipe is covered at all times to keep the prime. The pump will normally keep its prime by the liquid in the discharge pipework running back and filling the priming chamber once the pump has been switched off.



Pump must be completely filled with liquid before starting. Never allow pump to run dry in the hope it will prime itself. Serious damage to the pump will take place if this is allowed to happen.

- (h) Check suction and discharge piping and any other connections (eg. pressure gauge, temperature and flow control instruments) for correct operation.

5:2 STARTING

- (a) Close any drain valves in discharge line.
- (b) Open fully all valves in suction line.

- (c) Turn on flushing medium if required.
- (d) Prime Pump. If the pump does not prime properly or loses prime during start up, it should be shut down and condition corrected before the procedure is repeated.



Repeated trial start ups can overheat the motor. Starting currents are several time full load current - heating varies as the SQUARE of the current. Allow winding time to cool between starts.

- (e) For pumps moving high temperature liquids it is advisable to warm the pump prior to starting to avoid thermal shock on the materials used in the construction of the pump head eg., impeller, casing and backplate.
- (f) Start pump prime mover.



The discharge line valve should always be set to achieve the pump's minimum flow requirement usually achieved with a cracked discharge valve open slightly when pump is started. The excessive current required by the motor to start under full load will, in time, cause motor trouble.

- (g) When pump is operating at full speed open the discharge valve slowly.
- (h) Adjust seal flushing pressure on pumps fitted with external flushed seals. (See 4:5).

5:3 OPERATING CHECKS

- (a) Check pump and piping leaks.
- (b) Check and record pressure readings for future reference.
- (c) Check and record voltage, amperage per phase and kW.
- (d) Check temperature at various points on the pump to make sure that the pump is not overheating, especially in the area of the mechanical seal.
- (e) Check flow and pressure through seal flushing if fitted. (See 4:5).



Make all pump output adjustments with discharge valve. DO NOT throttle suction line to adjust pump output.

- (f) Check the suction pipe on self priming models to make sure that it is fully immersed at all times and that filter, if fitted, is clean.
- (g) When the pump is operated with a Variable Speed Drive, the operating speed range must be no lower than 50% of the rated speed and no higher than the rated speed.

5:4 SHUTDOWN

- (a) When stopping the pump always close the discharge valve first. Pump should never run dry for any length of time with this valve shut (see 4:4) or the suction valve closed or both closed, due to the damage of overheating and causing a meltdown of plastic parts of the pump.
- (b) Pumps fitted with external flushing type seals - leave flushing medium running for at least one hour after pump has stopped to dissipate heat generated by friction coupling travelling along the pump shaft.
- (c) In severe climate conditions the pump should be protected from freezing conditions when shut down by one of the following methods:
 - i. Drain pump and remove all liquid from casing if this liquid is liable to freeze solid.
 - ii. Keep fluid moving in the pump and pipework to insulate to prevent freezing.
 - iii. Heat pump and pipework to prevent freezing.



If heat is used to keep pump from freezing do not let temperature rise above 60 degrees centigrade unless permission to do so has been obtained from CREST PUMPS LIMITED.

ATTENTION

In freezing conditions it is important to keep pipework from freezing. A blockage in the pipe can result in overheating the pump (see 4:4). Also pumps with flushing type seals should have the flushing supply and return protected from freezing.

6 TROUBLE SHOOTING

Between regular maintenance inspections be alert for sign of motor or pump trouble. Common symptoms are listed in the following tables. Correct any trouble **IMMEDIATELY** to avoid costly repairs or shutdowns.

PROBABLE CAUSE OF SYMPTOM

NO LIQUID DELIVERED:

1. **Lack of Prime:** Fill pump and suction completely with liquid.
2. **Loss of Prime:** Check for leaks in suction pipe joints and fittings and for leaks through foot valve if fitted. Check vent casing and priming chamber if fitted, for accumulated air.
3. **Suction lift too high:** If no obstruction at inlet is found check suction for blockage. If pipework is clear check for friction losses in pipework eg: too long pipe run/too many bends/too small pipe size - check by measuring with a Mercury column or vacuum gauge while pump operates. If static head is too high the liquid level must be raised or the pump lowered.



While carrying out these checks the pump must not be allowed to run dry or serious damage may occur.

4. **Discharge head too high:** Check pipe friction losses (as suction lift) - larger piping may correct condition. Check that all valves are undersized for duty required.
5. **Speed low:** Check that the motor is receiving full voltage and the correct frequency. Also that it has been wired correctly or that the motor may have an open phase.
6. **Wrong direction of rotation:** Check motor rotation with directional arrow on pump and reverse rotation if required.

ATTENTION

Rotation is clockwise looking from motor to pump.

7. **Impeller completely plugged:** Dismantle pump and clean impeller.
8. **Air leaks in suction piping:** Check for leaks by painting joints with soap solution and plugging off pipework and putting line under pressure, soap solution will bubble where leak appears.
9. **Air leak via mechanical seal:** On single type seals replace or refurbish seal. On double type seals with flushing system check flushing pressure is correct and flushing liquid is on and the liquid is not aerated. Finally change and refurbish the inboard seal next to the pump.
10. **Speed too low:** See item No 5.
11. **Discharge too high:** See item No 4.
12. **Suction lift too high:** See item No 3.
13. **Impeller partially plugged:** See item No 7.

NOT ENOUGH LIQUID DELIVERED:

14. **Cavitation - Insufficient NPSH.**
 - (a) Increase positive suction head on pump by lowering pump or raising liquid level.
 - (b) Cool suction pipework at inlet to lower entering liquid temperature.
 - (c) Pressurise suction vessel.
15. **Foot valve too small or partially obstructed:** Area through parts of valve should be at least as large as area of suction pipe - preferably 1.5 times. If strainer is used net clear area should be 3 to 4 times area of suction pipe.
16. **Wrong direction of rotation:** See item No 6.
17. **Motor running but no flow:** Check impeller for a possible meltdown due to dry running or to liquid pumped being too hot.
18. **Suction inlet not immersed deep enough:** Air being sucked in due to eddies and a vortex effect. Lower suction pipe.

19. **Correct pressure but low flow rate:** Check with **CREST PUMPS LIMITED** to obtain the duty that the pump was originally sold for so that a check can be made against the duty required.

NOT ENOUGH PRESSURE

20. **Speed too low:** See item No 5.
21. **Air leaking in suction pipe:** See item No 8.
22. **Mechanical defects:** See item Nos 9, 15, 16 and 18.
23. **Obstruction in liquid passages or piping:** Dismantle pump and inspect passages of impeller and casing. If clear, check pipework and remove obstructions.
24. **Air or gases in liquid (lab. test liquid to see when bubbles occur):** It may be possible to overrate pump to the point where it will provide adequate pressure despite condition. It would be better to provide a gas separation chamber on the suction line near the pump and periodically exhaust accumulated gas.
25. **Too small impeller diameter:** Probable cause if none of the above. See item 20.
26. **Wrong direction of rotation:** See item No 6.
27. **Incomplete priming:** Exhaust all air from pump, priming chamber if fitted, piping and valves. (See 4:4 for correct method of installation).
28. **Suction lift too high:** See item No 3.
29. **Air leaks in suction pipe:** See item No 8.
30. **Air leaks mechanical seal:** See item No 9.

PUMP OPERATES FOR SHORT PERIOD THEN STOPS PUMPING:

31. **Air or gas in liquid:** See item No 25.
32. **Suction pipe uncovered:** See item No 19.

PUMP TAKES TOO MUCH POWER:

33. **Pumping too much liquid:** Consult **CREST PUMPS LIMITED** to obtain duty for which pump was sold. It might be possible to machine O.D. of impeller to correct the problem.
34. **Cavitation:** See item No 14.
35. **Mechanical defects:** See item Nos 15 and 18.
36. **Suction inlet not immersed:** See item No 19.

37. **Liquid heavier (in either viscosity or specific) than the pump was sold to handle:** Test liquid for viscosity and specific gravity. Reduce either or both to keep within motor power or change motor if possible to a larger size to handle the heavier liquid. Consult **CREST PUMPS LIMITED** before the latter step is undertaken.
38. **Casing distorted:** Check for signs of impeller face rubbing on boss. There should be a 0.75mm gap minimum between these faces on all plastic pumps running up to 50 degrees centigrade and a 1.5mm gap over 50 degrees centigrade. All metal pumps have a gap of 0.5mm.
39. **Shaft bent due to damage (pump or motor shaft on close coupled units or pump and pedestal shaft on long coupled units).** Check deflection of shaft with D.T.I. Total indicator reading should not exceed 0.05mm. A bent shaft will have the effect of closing down the impeller gap and causing the impeller to rub on casing creating greater flow and more contact friction which, in turn, takes more power.
40. **End float in motor:** This can cause impeller to rub on casing. Set impeller gap 0.75mm taking into account any end float in motor.
41. **Mechanical failure in critical pump parts:** Check impeller, mechanical seal and motor or bearing pedestal bearings. Any irregularity in these parts will cause drag.
42. **Speed too high: (Kw absorbed varies as the cube of the speed therefore any increase in speed means considerable increase in power demand).** Check voltage and frequency of motor.
43. **Electrical defects:** Check voltage, frequency and phase for compliance with motor nameplate. Also starting mechanism for same. There might also be a defect in either motor or starter. Check motor ventilation as it might be poorly sighted.
44. **Mechanical defects in motor or other types of drive:** If unable to correct troubles with cures outlined above or if other difficulties develop contact **CREST PUMPS LIMITED** and describe completely the operating conditions of the pump at the time of the failure along with any other relevant data.

7 MAINTENANCE

7:1 PREVENTIVE MAINTENANCE

A pump properly installed and operated will require a minimum of maintenance. For the best overall performance be sure to adhere to the instructions in this manual.

Operating conditions vary so widely that to recommend one schedule of preventative maintenance for all duties covered by our pumps is not possible. Keep a permanent record of the periodic inspection and maintenance performed on the pump.

The recognition of maintenance procedure will keep the pump in good working condition and prevent costly breakdowns.

One of the best rules to follow in proper maintenance is to keep a record of actual operation data and hours of operation. The length of this operation period will vary with different applications and can only be determined from experience. The next

inspection can be scheduled based on the condition of the components at the first inspection. This system can be followed until a maximum period of operation is reached, which should be considered the operating schedule between inspections. A guide for performing periodic inspections on the pump follows:

PERIOD	INSPECTION
Monthly	Check bearing in motor and bearing pedestal when fitted for temperature and wear. A bearing that has become noisy is obviously showing signs of wear. Check condition of mechanical seal/s and operation of seal flushing system if fitted.
3 Monthly	Monthly checks plus check for leaks from pump and pipework and repair as required.
6 Monthly	Monthly and 3 monthly checks. Inspect operation of all valves and instrumentation for correct operation. Special attention to be paid to non-return and foot valves, if fitted, as poor operation of these valves can result in poor performance of the pump.
Yearly	All previous checks, also remove rotating element and inspect for damage and wear, ordering replacement parts if necessary. Remove any deposit or scaling with particular attention to the mechanical seal area. Measure total dynamic suction and discharge head as a test of pipe connections. Record figures and compare them with the figures of the next test. This is important especially where the fluid being pumped tends to form a deposit on internal surfaces.

Recommended 2 Year Spares

It is recommended to the following parts are replaced every two years: mechanical seal, shaft sleeve, all o-rings.

LUBRICATION

7:2

All bearings are of the double shielded pre-packed for life type and cannot be lubricated.

ATTENTION

Bearing temperature should not rise above 95 degrees centigrade otherwise the pre-packed grease will run out.

In the event of high temperature bearings being fitted this will be shown on the Service Record and Data Sheet (See 2:1).

7:3 **DISMANTLING INSTRUCTIONS**



Never attempt to dismantle the pump unit until it has been disconnected from the mains electricity supply and, when it has been disconnected from the suction, discharge and seal flushing pipework, ensure that the pump is thoroughly de-contaminated of the fluid it has been pumping before dismantling.

These instructions are a general guide to dismantling the **CREST PUMPS LIMITED** range of end suction pumps and you should only follow the relevant parts of these instructions appertaining to the pump you have purchased.

- a) Remove the pump to a safe and clean working area.

Start by removing the protective guard which is secured to the pump adaptor by bolts. Also remove the coupling guard if the pump is long coupled. Remove the motor retaining bolts from the baseplate on a close coupled pump or the pedestal bolts on a long coupled pump.

Remove the bolts and washers that secure the adaptor/impeller assembly to the casing assembly then separate.

Holding the 'C' coupling that holds the pump shaft to the driving shaft, unscrew the impeller locknut which has a **RIGHT HAND** thread. Take care not to lose the 'O' ring fitted onto the face of the impeller which the locknut seals against. Remove this 'O' ring and store safely if it is to be re-used. Pull the impeller off the shaft square or key.

On pumps fitted with an external PTFE bellows type seal (MSC) remove backplate complete with the seal seat, clamp plate and guard. Slacken the two seal securing screws, (do not remove). Pull the rotary part of the seal off the shaft sleeve followed by the shaft sleeve.

On pumps fitted with single or double internal seals, unscrew and remove the seal housing bolts and washers. Remove the backplate and pull the seal assembly off the shaft sleeve followed by the shaft sleeve.

Pumps with double mechanical seals must have any connection to the seal housing removed before the backplate can be pulled away from the adaptor.

At this point you can check the condition of the mechanical seals.

Should you need to remove the seat, unscrew the bolts that hold the seal clamp plate in position and lift off clamp plate and the seal seat will now lift out of its location in the backplate. Take off the two PTFE gaskets - one on each side of the seat. On double or single internal seal applications the seal seat in the backplate, housing or seal plate can be pushed out by finger pressure for examination.

Check and note in which position each seal seat is located so that if they are to be re-used they are put back in the correct position or, if new seals are to be fitted, that the new seats must be fitted to the same positions as the old seals.

The pump is now dismantled far enough to change the mechanical seals.

- (b) If the pump shaft is to be removed, loosen the clamping bolts of the 'C' coupling sufficiently to allow the two flanges of the coupling to be prised apart to release the pressure on the clamping sleeve. When the coupling pressure has been released the pump shaft can be pulled off the driver shaft.

To remove the adaptor from the driver, remove the four bolts, nuts and washers that secure the two parts together and pull the adaptor off the locating spigot of the driver.

To dismantle the casing assembly remove the flange bolts and flanges. Remove the front cover plate nuts and washers and split the cover plates from the casing. Press out the suction and discharge branches. Remove the o rings.

- (c) On long coupled pumps which are fitted with a bearing pedestal the following procedure should be observed if any work is to be carried out on the bearing pedestal.

Loosen locking screw in half coupling and draw the half coupling off the bearing pedestal shaft. Remove the coupling key, unscrew the bearing retaining nut (**RIGHT HAND THREAD**). Remove the adjusting bolt and unscrew the bearing housing.

The bearing shaft is now ready for removal, either by pressing out of the bearing or using a soft drift and a hammer on the motor coupling end of the shaft. Next remove the three screws in the bearing retaining plate and lift off the retaining plate. Using a soft drift and hammer remove the two bearings from the bearing pedestal -during this operation remove the bearing spacer. The bearing pedestal assembly is now completely dismantled and ready for new parts to be fitted.

- (d) Should only the prime mover need removing follow steps (b) 1 & 2 taking care not to damage the pump head assembly. On pumps long coupled through a bearing pedestal the following steps should be taken:

Remove coupling guard and the four bolts that retain the prime mover to the baseplate. Pull prime mover away from the bearing pedestal and pump

DISMANTLING INSTRUCTIONS (cont)

assembly which will split the drive coupling. Take care not to loose the rubber coupling spider, leave the coupling spider on the pump half coupling ready for re-assembly. Remove the prime mover to a safe place of work and carry out necessary repairs.

Should only the mechanical seal/s need replacing steps (a) 1-4 and 5,6 or 7 (as required by the seal arrangement fitted to the pump) should be followed.

The priming chamber can be removed either from the pump or left attached to the baseplate and pipework and the pump taken away by unscrewing the connecting union or bolted flanges. Take care not to loosen connections in pump or priming chamber or lose the gasket in the connection.

7:4 ASSEMBLY INSTRUCTIONS

To assemble the **CREST PUMPS LIMITED** range of end suction pumps the reverse of the dismantling instructions should be applied. The following points should be observed during assembly:

1. Check all parts that are being re-used to ensure they are clean and free from damage.
2. Check all new parts being fitted to ensure they are the same as the parts being replaced. Special attention needs to be taken with the seal/s arrangement to ensure the correct mechanical seal/s are fitted. When double flushing type seals are used the correct inboard and outboard positions must be maintained. Also if pumps are fitted with a double flush seal housing, care must be taken not to over-tighten the inlet and outlet flushing connections and note that the length of the thread on the connections should not protrude through into the seal compartment. As the running clearance between the seals and seal housing is only 1.5mm any protrusion of the connections will impinge into the seals causing them and the impeller to wear rapidly.
3. When re-fitting or fitting a new pump shaft to the prime mover shaft make sure it is a tight hand-push fit onto the prime mover shaft. This is required so that the impeller gap can be set when the pump is assembled.
4. The impeller gap (as noted on 2:1) must be checked and adjusted if necessary to maintain the capacity of the pump. This can be done on all models by inserting the correct size of feeler gauge down through the discharge port into the gap between the impeller and the casing boss.
5. The impeller gap cannot be set until the pump has been fully assembled. To set the impeller gap proceed as follows:

Close coupled pumps.

Ensure all 'C' coupling clamp bolts are loose and the pump shaft moves on the prime mover shaft when levered by placing a large screwdriver through the adaptor and behind the pump shaft. Lever the pump shaft forward until the impeller touches the casing boss. Then, using the shaft of a hammer

ASSEMBLY INSTRUCTIONS (cont)

placed through the suction port, gently tap the impeller away from the casing boss until the correct impeller gap has been obtained between the front face of the impeller and the casing boss. When satisfied, tighten the 'C' coupling which should be as near the end of the pump shaft as possible. Start tightening procedure by selecting one bolt and tighten sufficiently to just pinch the two flanges together. Then, moving in a clockwise direction tighten all the remaining bolts to the same degree. Make sure the gap in the centre of the 'C' coupling is uniform all round otherwise the clamping effect and the friction drive will be affected. Once the bolts have been pinched up initially, proceed to tighten each bolt in turn, one flat at a time maintaining the centre gap until all the bolts are fully tightened. Re-check impeller gap when the 'C' coupling is fully tightened.

To set gap on Long coupled pumps rotate the rear bearing plate which will move the shaft/impeller assembly forward onto casing as previously described then unscrew until the correct gap is obtained then refit the locking bolt.

6. All sealing faces i.e. casing to backplate, backplate to seal housing, are sealed using an o ring or gasket. It is advisable to replace any of these once disturbed. Also the impeller locknut should be secured with Loc-tite 242 E Nut Lock.
7. On long coupled units, make sure the drive coupling alignment is correct.
8. Re-install the pump as described in 5:1, 5:2 and 5:3.

7:5 REPLACEMENT PARTS

Pumps are designed and built with all wearing parts being replaceable. A recommended inventory of spare parts is dependent upon installation and the importance of continued operation.

For normal service, all items are listed on the Service Record and Data Sheet (2:1).

Parts should be ordered as far in advance as possible since circumstances beyond the control of the Company may reduce existing stock. Not all parts are stocked as some must be manufactured for each order.

When ordering spare parts always include the following information:

Pump Serial Number and/or Pump Type
Part number obtained from drawing/parts list
Name of part and quantity of part required
Material desired (if different from original material)
Full Company details including delivery/invoice address
Order Number.

NOTE:

Parts will be supplied in the original materials unless specified as a material change. All material substitutions should be discussed with **CREST PUMPS LIMITED.**

SUBJECT:- PUMP RETURNS C.O.S.H.H. REGULATION

Due to the current C.O.S.H.H. regulations it is now company policy that all pumps returned to us must be accompanied with documentation stating what product the pump has been handling and that the pump has been thoroughly cleaned. This documentation should be securely attached to the returned item and be clearly visible.

We regret that failure to attach the required documentation could result in the pump not being accepted into our 'goods in' department. We are sure you will appreciate, bearing in mind the current Health and Safety Regulations, that this is a measure we are having to take and would request that you make all relevant personnel within your organisation aware of these arrangements.

A sample form is attached for your use when returning any items to our factory.

CERTIFICATE

The pump and its accessories submitted by us for inspection/repair,

T: 01425 627700

W: www.crestpumps.co.uk

A: 7 Queensway, New Milton, Hampshire, BH25 5NN



Pump Return Form

All pumps returned to us must be accompanied with this completed form stating what product the pump has been handling and that the pump has been thoroughly cleaned. This documentation should be securely attached to the returned item and be clearly visible. If not, the shipment shall be rejected and returned to the sender

Date Sent:		Company Name:	
Contact Name:		Tel No:	
Email Address			
Pump Type:		Serial Number	
Liquid(s) this pump has been handling (please supply MSDS where possible)			
Are they a health hazard?	Yes / No	Do they give off dangerous products after thermal decomposition?	Yes / No
If yes to either of the above, please provide further information:			
Reason for Return:			

Legally Valid Declaration: I, as the undersigned, have the skills to judge and confirm this pump has been safely cleaned and drained before despatch. If not adequately cleaned, we accept the pump maybe rejected and/or we will be liable for the chemical cleaning and waste disposal costs. We commit to exempting Crest Pumps Ltd from any claim for damages by third parties that have occurred due to incomplete or erroneous information. We are aware that, independently from this statement, we are directly accountable to third parties, particularly with respect to Crest Pumps Ltd personnel responsible for handling or repairing the product.

Name of authorised Person (please print): _____ Date _____

Signature: _____

Please return to:

Crest Pumps Ltd
7 Queensway
New Milton
Hampshire
BH25 5NN

Please note that if we do not receive a response within 60 days of our inspection report / quote, we reserve the right to scrap the pump without further notice.

CRESTPUMPS CHEMICAL PUMPING SOLUTIONS



www.crestpumps.co.uk

T: 01425 627700

7 Queensway, New Milton, Hampshire,
BH25 5NN