



Installation / Operation / Maintenance Manual

TYPE PL

Model: PL-40x25-160 PL-40x25-200 PL-40x25-200LF
 PL-50x25-250LF PL-50x40-160 PL-50x40-200
 PL-50x40-250 PL-80x50-160 PL-80x50-200
 PL-100x80-160

Table of Contents

1. General	03
2. Safety instructions before use	03
2.1 DO NOT RUN PUMP DRY.....	03
2.2 Influence of rare earth permanent magnets.....	03
2.3 Notice of pump using in different locations.....	04
2.4 Function of dry run protector.....	04
3. Preliminary check	04
3.1 Package appearance confirmation.....	04
3.2 Inner contents confirmation.....	04
3.3 Pump rotating parts confirmation.....	05
3.4 Name plate check.....	05
3.5 Spare parts storage.....	05
3.5.1 Short term storage.....	05-06
3.5.2 Long term storage.....	06
3.6 Pump handling.....	07
4. Pre-installation inspection.....	07
4.1 Installation location / Environment.....	08
4.2 Pump body inspection.....	08
4.3 Piping inspection.....	08
5. Installation / Piping / Wiring.....	08
5.1 Suggestion of installation.....	08
5.2 Suction piping.....	09
5.2.1 General requirements.....	09
5.2.2 Inlet piping.....	10
5.2.3 Foot valve.....	10
5.2.4 Self-priming cylinder.....	10
5.2.5 Control valve.....	10
5.2.6 Filter system.....	11
5.3 Discharge piping.....	11
5.3.1 General requirements.....	11
5.3.2 Priming piping.....	11
5.3.3 Pressure gauge.....	11
5.3.4 Check valve.....	12
5.3.5 Control valve.....	12
5.3.6 Exhaust valve.....	12
5.4 Electrical connections.....	13
6. Operation & Start-up.....	13
6.1 Pre-operation inspection.....	13-14
6.2 Start-up sequence.....	14
6.3 Operation precautions.....	15
6.4 Shutting down the pump precautions.....	15
7. Maintenance and inspection instructions.....	16
7.1 Daily inspection.....	16
7.1.1 Visual inspection.....	16
7.1.2 Operating inspection.....	16
7.2 Periodic inspection.....	16-17
8. Troubleshooting.....	18-22
9. Pump construction chart.....	23
9.1 (132).....	23
9.2 (160).....	24
10. PL Torque for bolts and nuts.....	25
11. Repairs and guarantee.....	26

1.General

Thank you for selecting the PTCXPUMP stainless steel magnet drive pump. In order for you to achieve and ensure that pump is in perfect operating condition with unique performance of PTCXPUMP pump, please be sure to read this manual before using it. Failure to follow this operating instruction may cause serious personal injuries and/or equipment damage.

2.Safety instructions of before use

2.1 DO NOT RUN PUMP DRY

Frictional heat generated under dry run conditions (without liquid inside the pump) can cause damage to the pump. Operating the pump with the suction valve fully closed will result in dry operation.

2.2 Influence of rare earth permanent magnets

The rare earth permanent magnets in this pump have been manufactured such that the magnetic field is directional toward each half of the magnetic coupling. For this reason, the magnetic field that exists outside of the assembled magnetic coupling is minimal. When the two halves are apart, the magnetic field is exposed, which is why we recommend that personnel wearing medical devices DO NOT HANDLE the magnetic coupling components. When the pump is assembled, the magnetic fields from the magnetic coupling components are not exposed and it is safe for those who wear medical devices to be in the general proximity of the assembled pump, whether the pump is in operation or not.

2.3 Notice of pump using in different locations

Each pump is designed according to the operating conditions provided by the customer. If it is necessary to move the pump to another location, please contact our company or your local distributor to confirm the new operating conditions are suitable for it. In accordance with pump operating conditions change (temperature, concentration, viscosity, specific gravity, etc.) may cause abnormal operation of the pump.

2.4 Function of dry run protector

To prevent pump run dry or other issue cause pump damage, we suggest install a pump DRY RUN PROTECTOR.

3.Preliminary check

3.1 Package appearance confirmation

After receive the pump, please check the outer packaging box or the pump body (the packaging method will depend on the size of the pump) for potential physical damage during by the transportation process. If any damage is found, please notify the transportation company and our company or your local distributor immediately to confirm the attribution of responsibility and promptly handle it.

3.2 Inner contents confirmation

The contents of the shipment will contain: pump, pump test report and operation Manual. If any item is missing, please contact our company or your local distributor immediately and promptly handle it.

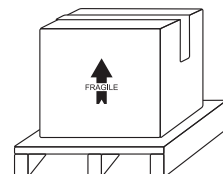

3.3 Pump rotating parts confirmation

Use a small screwdriver to rotate the impeller of the motor's cooling fan. The fan should turn easily. If the fan feels tight or if there are unusual sounds, the interior of the pump may have been damaged during shipping. Please contact our company or your local distributor immediately and promptly handle it.

3.4 Name plate check

Check the nameplate on the pump against receiving and purchase documents to be sure there is the correct pump model, pump head, flow rate, frequency and materials of construction have been supplied. If a motor has been supplied, check for correct enclosure, horsepower, speed, and voltage.

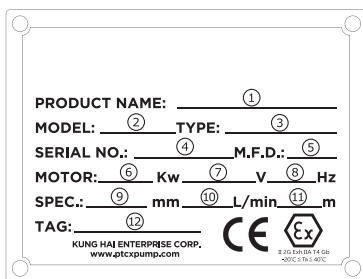

Nameplate content explanation

- | | |
|--------------------|--|
| ① Product name | ⑧ Motor frequency |
| ② Product model | ⑨ Suction & discharge Size |
| ③ Product type | ⑩ Flow rate |
| ④ Serial number | ⑪ Head |
| ⑤ Manufacture date | ⑫ Subsidiary information
(Use for TAG, fluid name,
material, etc.) |
| ⑥ Motor power | |
| ⑦ Motor voltage | |

3.5 Spare parts storage

3.5.1 Short term storage

- Do not remove the sticker on the suction and discharge flanges before the pump is connecting to pipe line to prevent foreign objects and dust enter.
- The storage location should be dry and well ventilated to prevent excessive moisture.

- It is recommended to use tape to seal the junction box hole to avoid foreign objects and dust enter.
- If the pump is used in a cold and frozen area, please drain and empty the liquid from the drain hole to avoid the problem of liquid freezing.
- If the used pump will be stored, please follow the steps below:
 - » Use the clean water to flush internal and dry inside.
 - » Seal the suction and discharge flanges to avoid foreign objects and dust enter.
 - » If the pump storage time exceeds one year or more, please check all the screws are tightened. Remove the motor fan cover

and turn the fan to check the smoothness of the rotation. If cannot judge whether it can be used, the pump can be sent back to our factory for maintenance or contact with your local distributor for solution.

3.5.2 Long term storage

- Same as short-term storage.
- Remove the motor fan cover every one to three months, turn the fan by hand and check the rotation smooth.
- If the pump storage time exceeds one year or more, please check all the screws are tightened. Remove the motor fan cover and turn the fan to check the smoothness of the rotation. If can not judge whether it can be used, the pump can be sent back to our factory for maintenance or contact with your local distributor for solution.
- Because the gasket is made by plastic, it will react to the shrinkage and thermal expansion as the environment changes. It is recommended to replace the gasket if stored more than one year before operation. If cannot judge whether it can be used, the pump can be sent back to our factory for maintenance or contact with your local distributor for solution.

3.6 Pump handling

Before lifting the pump, please check and understanding the total weight of the pump with motor and use the loadable rope or lifting device to prevent the pump falling and injury the operator.

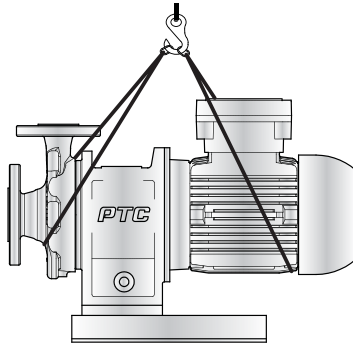

4. Pre-installation inspection

4.1 Installation location/Environment

- The foundation should be firm and heavy to reduce vibration. A concrete foundation with a solid baseplate is recommended.
- Avoid installation in humid and dusty environments. If necessary, please install protective covers.
- The installation location should be as low as possible and close to the liquid supply source.
- There must be sufficient space for the installation location for future maintenance.
- The pump and its wiring should be placed in a relatively dry environment, protected from possible flooding.
- Motor selection requires inspection of the installation location requirements, such as outdoor, indoor, explosion-proof or non-explosion-proof specifications.
- Pump install area tempertaure $-20^{\circ}\text{C} < \text{Ta} < 40^{\circ}\text{C}$.
- Ingress Protection Ratings: IP66

4.2 Pump body inspection

Before starting pump, please check if all the screws are tightened and remove the motor fan cover and turn the fan to check the smoothness of the rotation.

4.3 Piping inspection

Check for foreign objects in the inner piping and make sure all the screws are tightened.

5.Installation / Piping / Wiring

5.1 Suggestion of installation

Fig.1

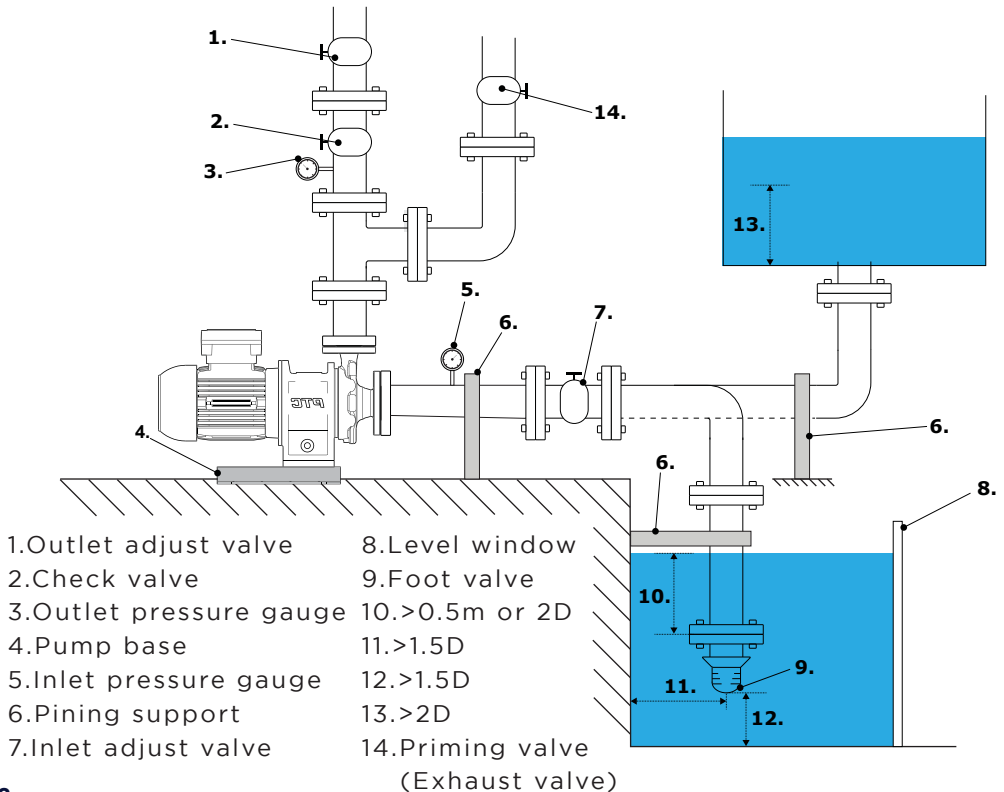

5.2 Suction piping

5.2.1 General requirements

- Suction condition must satisfy $NPSHa > NPSHr + 0.5m$.
- Reduce inlet head as much as possible, use straight and short piping.
- The pipes should have adequate structural support and should not use the pump as its primary support.
- Inlet piping and connectors should be installed properly to prevent drawing in air.
- The piping system should not have upward bumps that may collect air. The inlet piping should also have a 0.01-0.02 (slope increase towards the pump.
- There should not be any elbows for at least 5 times the pipe diameter from the opening of the pump. The elbow closest to the pump opening should be a long radial elbow.

Fig.2

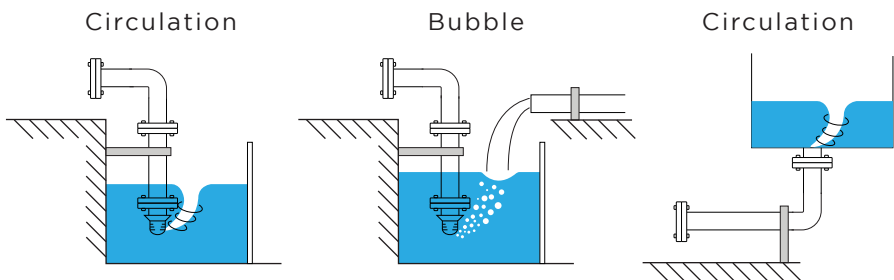

5.2.2 inlet piping

- There should be at least a 1.5 diameter distance between the pipe inlet and closest tank wall to prevent circulation.
- The submerge depth of the inlet should be at least 0.5m or at least twice the pipe diameter below the liquid surface.
- There should be a distance of at least 1.5D between the bottom of the tank and the beginning of the inlet pipe opening.
- If there are two or more inlet piping in the same tank, they should be placed at least 3D apart to prevent mutually disrupting each other's flow.

5.2.3 Foot valve

- Please install a foot valve if upward suction is used.

5.2.4 Self-priming cylinder

- If suction method is upward suction, please install a self-priming cylinder to prevent dry-running due to leaking foot-valve.
- The side of the self-priming cylinder should have a minimum liquid level of at least 0.5m above the opening of the pump.

5.2.5 Control valve

- A control valve should be installed to make disassembling of the pump easier. The valve should only be shut off when the pump is to be detached for maintenance or repairs.
- We recommend the use of valves that have the least loss when fully opened, like a gate valve.

5.2.6 Filter system

- It is generally not recommended to install a filter in front of a pump, which can unpredictably increase suction system resistance.
- If a filter has to be used, it should be cleaned regularly to ensure a smooth flow.

5.3 Discharge piping

5.3.1 General requirements

- The weight of the outlet piping should be properly supported to prevent putting excessive stress on the pump.
- A priming piping must be installed if the suction system does not employ positive pressure, i.e. upward suction.
- The flow rate in the outlet piping should not exceed 3m/sec.
- The ability of each component in the piping system to withstand pressure should be calculated to determine the maximum allowable operating pressure.

5.3.2 Priming piping

- Upward suction pumps that do not have a self-priming cylinder should have a priming piping system.

5.3.3 Pressure gauge

- Pressure gauge used should be able to read beyond the maximum operating pressure.
- Pressure gauge should be made of material that is corrosive resistant, otherwise a diaphragm should be used.
- A valve can be installed on the piping that leads to the pressure gauge, to facilitate maintenance and to lengthen the gauge's service life.

- During operation if the pressure gauge reading fluctuates, either there are air bubbles in the system or cavitation has occurred.

5.3.4 Check valve

A check valve should be installed in the following situations:

- Outlet piping is long.
- Head of outlet is more than 15m
- Discharge pressure exceeds 2kg/cm^2 and flow rate exceeds 3m/sec .
- Two or more pumps share the same outlet piping system.
- To prevent back flow (water hammer) from damaging the pump during unexpected power outages.

5.3.5 Control valve

- A adjust valve can be used for controlling the flow of fluids. Do not run the pump with adjust valve closed for an extended period of time.
- When starting the pump, always start with a closed valve and then slowly open the valve to obtain the desired operating pressure and flow. Always open or close the valve gradually.

5.3.6 Exhaust valve

- A vent should be installed if the horizontal section of the outlet piping is very long.

5.4 Electrical connections

The electrical connection should be carried out by an authorized electrician in accordance with local regulations. Please make sure that the electrical data on the nameplate of the motor correspond to the electricity supply on which it will be used. Motors must be connected to a motor protection switch.

- Use an electromagnetic switch that conforms with the specifications (voltage, capacity, etc.) of the pump motor.
- If using the pump outdoors, waterproof the wiring to protect the switches from rainwater.
- Electromagnetic switches and push buttons should be installed reasonably distant from the pump.

** Refer to the instruction manual of the motor issued by the motor maker for detailed handling instructions.*

6.Operation & Start-up

*Dry operation of the pump (pump operation without liquid inside) may cause damage to the pump internally. Never operate the pump dry. The rotating parts are self-lubricated and self-cooled by operating liquid. If the pump is operated dry or with the suction-side valve closed, damage may result.

6.1 Pre-operation inspection

- Use the screwdriver to rotate the motor's fan to ensure it is not too tight or stuck.
- Check the motor's power rating, including frequency, voltage and wiring.
- Recheck and make sure all the parts (flange, pump casing, base plate, etc.) are securely fastened.

- Fill the pump with liquid (priming) to remove any air within the pump and suction piping.
- Check and make sure all the inlet valve of the system is open.
- Make sure before start-up the pump, and exhausted the inlet piping system and pump internal air.

6.2 Start-up sequence

- Before start-up the pump make sure inlet piping system and pump internal chamber there is no air residue, if there is air inside, please open the outlet valve remove the motor fan cover and manually rotate motor fan to vent.
- After finished vent, please close outlet valve and check the direction of rotation of motor by instantly switching on and off the power, the direction of rotation can be checked from the motor fan side, it should be clockwise seeing from the fan cover.
- If the rotating direction is reversing, please check the motor wiring followed by motor junction box.
- Before start-up the pump, piping outlet valve need to be fully close.
- When pump start-up, the inlet pressure will be rise, if the pressure does not rise or pressure insufficient, please shut down the power and check the piping system or wiring again.
- When pump start-up (outlet valve close), please check the shut-off current value of the motor is match with testing report or not, when the current value is reached to value, then slowly open outlet valve.
- Slowly open outlet valve and adjust to obtain the desired operating pressure and flow rate.
- Check the pump's unusual sound, vibration, outlet pressure and motor current value are match with testing report or not.

6.3 Operating precautions

- Regularly check for pressure gauge, current valve, etc. data.
- Shut down power immediately in the case of cavitation or dry-running. When dry-running happens DO NOT give liquid immediately, it might happen SiC parts cracking due to high temperature thermal shock
- If decoupling should happen, shut down the pump to prevent reducing the magnet's strength.
- During power outage, shut off the power supply and close the outlet valve.

6.4 Shutting down the pump precautions

- Close the outlet valve slowly, DO NOT close outlet valve urgently to prevent damage to pump due to reverse fluid flow (water hammer)
- Shut off the pump, motor should stop gradually. If not, please check the interior of the pump for problems.
- The pump should be checked periodically, if the pump is used in a cold operating environment (relative to the fluid's freezing point), the fluid may crystallize even if the pump is shut down for a very short amount of time. To prevent crystallization, a drain plug should be included in the piping system or a heating system could be used to maintain the temperature during shutdown.

7. Maintenance and inspection instructions

7.1 Daily inspection

7.1.1 Visual inspection

- check for corrosive or damaged of the front casing, bracket, and base plate.
- Check for leakage of pump and piping system.
- Check the pump and motor surface for physical damage such as corrosion, paint peeled off.

7.1.2 Operating inspection

- Check for the unusual sounds and vibrations when pump is running.
- Check for any abnormal overheating on the surface of motor, current and motor loading, noise, foreign objects blocking the vent of fan, etc.
- Check for liquid level in tank and inlet & outlet pressure.

7.2 Periodic inspection

- The following item should be inspected in every three months.
- If there are spare pumps should be inspected and regularly test running.

Periodic inspection chart

Parts name	Inspection item	Solution
Front & rear casing	a.Any crack on the surface	Replace
	b.Unexpecting scratch marks	Contact the supplier
	c.Crystallization and sludge	Clean
Gasket / O-ring	a.Deformed, corroded or swollen	Replace and contact the supplier
Impeller and inner magnet	a.Surface scratch marks or cracks	Contact the supplier
	b.Surface cracked or crystallization	Contact the supplier
	c.Cavitation or corrosion marks	Contact the supplier
	d.Impeller clogging	Clean
	e. Dimensional change in impeller	Contact the supplier
Shaft / Bearing / Thrust ring / Bushing	a.Surface scratch marks	Contact the supplier
	b.Surface cracks	Contact the supplier

8. Troubleshooting

Problem	Symptoms	Cause	Solution
Liquid is not being pumped	No suction or discharge pressure, Pump power usage is very low	Pump not primed	Re-prime pump and verify that suction pipe is full of liquid, check the suction pipe for high points that can trap air
	Suction gauge reads much lower than normal	Suction pipe clogged	Confirm that any suction valve or control valve is not stuck shut, inspect suction pipe for blockage
	Suction gauge reads normal, pump generates full discharge pressure but no flow	Discharge pipe clogged	Confirm that any discharge valve or control valve is not stuck shut, inspect discharge pipe for blockage
	Discharge pressure is only slightly higher than suction pressure	Clogged impeller	Open pump and clean blockage from impeller
	No discharge pressure, pump makes loud buzzing noise, increased vibration	De-coupled impeller	Shut off pump, verify that the motor fan spin smoothly by hand, if motor will not spin by hand, open pump for inspection
	If motor spins smoothly by hand, confirm that the impeller is sized for operating conditions and liquid specific gravity		
	Verify the viscosity of the liquid is not too high, impeller or outer magnet may be weakened if overheated		

Problem	Symptoms	Cause	Solution
	Pump generates full discharge pressure but no flow, pump casing and pipes immediately before and after pump heats up	Head requirement higher than anticipated	Confirm that discharge line is not blocked or valve is not stuck shut
		Undersized impeller	Pump may require a larger impeller or overcome system head
Pump not delivering desired head or flow	Suction pressure is negative (Gauge pressure)	Air leak in suction line	Located and seal the air leak
	Discharge pressure is lower than normal		
	Discharge pressure is lower than normal, flow rate is decreased, pump is noisy, increased vibration	Insufficient NPSH	Check liquid level in suction tank
			Check suction piping for restrictions or obstructions
			Verify vapor pressure and temperature of process liquid
			Pump should be located as close to the source as possible
	Discharge pressure is lower than normal, flow is reduced	Backward rotation	Verify motor rotation and correct if necessary
	Pump does not reach desired flow rate	Head requirement higher than anticipated	Increase motor speed
Undersized impeller		increase impeller size	
Suction gauge is very low	Strainer device is full / clogged(if equipped)	Clean / empty strainer basket	

Problem	Symptoms	Cause	Solution
Pump starts and immediately stops pumping	Discharge pressure rises then falls	Pump is not properly primed	Re-prime pump and verify that suction pipe is full of liquid, check the suction pipe for high points that can trap air
	Pump power usage is very low after pressure drops		
	Discharge pressure rises then falls, pump makes a loud buzzing noise, increased vibration	De-coupled impeller	Confirm that the impeller is sized for operating conditions and liquid specific gravity
			Verify the viscosity of the liquid is not too high, impeller assembly of outer magnet may be weakened if overheated
Pump operated normally but stops pumping & loses prime, pump will not run until priming chamber is re-filled	Suction pipe volume too large for priming chamber	Calculate volume of the suction pipe, it is recommended that the priming chamber volume should be 3 times the suction pipe volume	
		Decrease suction pipe volume	
		Move pump closer to source	
Pump uses excessive power	Burning smell coming from back of pump	Outer magnet installed improperly	Confirm that the groove on the outer drive lines up with the edge of adapter and is properly tightened
	Decreased flow	Damaged or broken SiC ring	Inspect the pump and replace damaged components
	High power		
	Consumption		
	High vibration		
Noisy operation			

Problem	Symptoms	Cause	Solution
	Pump delivers the required flow and head, but power consumption is high, high discharge pressure	Specific gravity or viscosity higher than expected	Determine liquid viscosity and specific gravity, verify the actual power consumption is correct
	Pump will produce the rated flow, discharge head may be decreased, power will be higher	Clogged impeller	Open pump and clean blockage between impeller and bushing
Pump is noisy or vibrates	No discharge pressure, pump makes a loud buzzing noise, increased vibration	De-coupled impeller	Shut off pump, and verify that the motor spins smoothly by hand, if motor will not spin by hand, open pump for inspection
			If motor spins by hand, confirm that the impeller is sized for operating conditions and liquid specific gravity
			Verify the viscosity of the liquid is not too high, impeller or outer magnet may be weakened if overheated
	Flow and head are normal, pump or pipes vibrate	Piping or pump not properly anchored	Tighten mounting bolts on pump feet and base plate, confirm that the suction and discharge Pipes are properly supported per hydraulic institute recommendations

Problem	Symptoms	Cause	Solution
	Discharge pressure is lower than normal, flow rate is decreased, pump is noisy, increased vibration	Insufficient NPSH / pump is cavitating	Check liquid level in suction tank
			Check suction piping for restriction or obstructions
			Verify vapor pressure and temperature of process liquid
			Pump should be located as close to the source as possible
		Partially clogged of inside pump parts	Open pump and clean blockage from parts

9. Pump construction chart

9.1 (132)

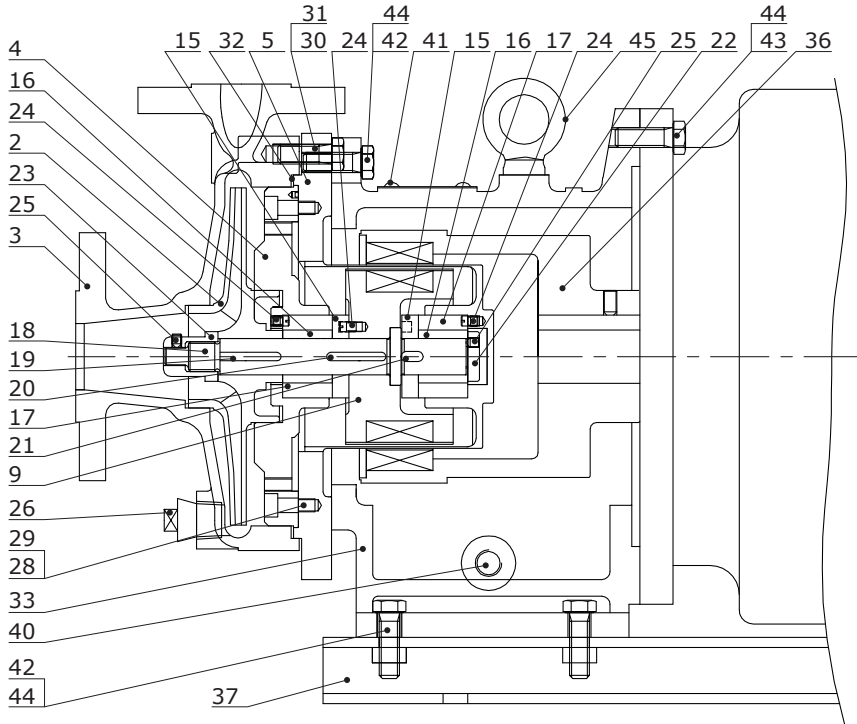

No.	Parts Name	Material	Qty.
2	Impeller	SUS316L	1
3	Front Casing	SUS316L	1
4	Casing Cover	SUS316L	1
5	Rear Casing	SUS316L	1
9	Inner Magnet Coupling	SUS316L+RearEarth	1
16	Sleeve	SIC	2
17	Bushing	SIC	2
15	Thrust Ring	SIC	2
18	Shaft	SUS316L	1
19	Impeller Key C5*37	SUS316L	1
20	Coupling Key A5*36	SUS316L	1
21	Thrust Ring Key A6*13.5	SUS316L	1
22	Shaft Bolt	SUS316L	1
23	Impeller Nut	SUS316L	1
24	Set Screw	SUS316L	3
25	M6*8L Set Screw	SUS316L	2

No.	Parts Name	Material	Qty.
26	Plug R1/2"	SUS316L	1
28	M8*20L Hexagon Socket Screw	SUS316L	4
29	M8 Spring Washer	SUS316L	4
30	M12*35L Hexagon Screw	SUS316L	8
31	M12 Washer	SUS316L	8
32	Gasket Ø219*Ø205*1.5t	PTFE	1
33	Adapter	FC25	1
36	Outer Magnet Coupling	SS400+RareEarth	1
37	Baseplate	SS400	1
40	Plug R3/8"	PP	1
41	Nameplate	SUS304	1
42	M12*35L Hexagon Screw	SUS316	8
43	M12*40L Hexagon Screw	SUS316	4
44	M12 Washer	SUS316	12
45	M12*20L Ring	SS400	1

9.2 (160)

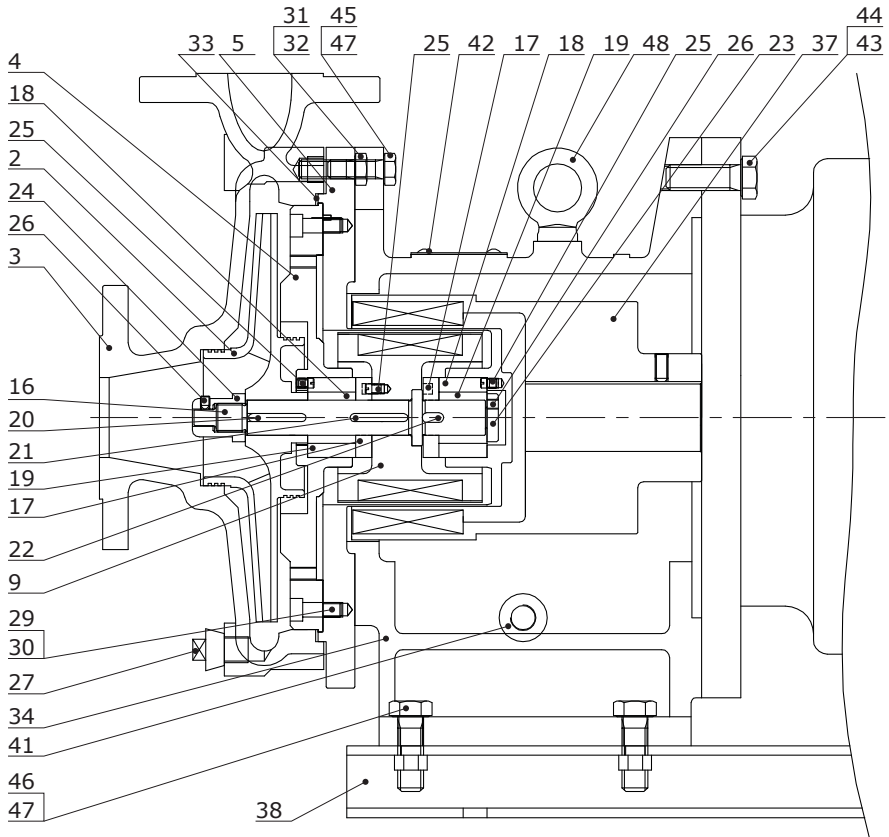

No.	Parts Name	Material	Qty.
2	Impeller	SUS316L	1
3	Front Casing	SUS316L	1
4	Casing Cover	SUS316L	1
5	Rear Casing	SUS316L	1
9	Inner Magnet Coupling	SUS316L+RareEarth	1
16	Shaft	SUS316L	1
17	Thrust Ring	SiC	2
18	Sleeve	SiC	2
19	Bushing	SiC	2
20	Impeller Key C5*37	SUS316L	1
21	Coupling Key A5*36	SUS316L	1
22	Thrust Ring Key A6*13.5	SUS316L	1
23	Shaft Bolt	SUS316L	1
24	Impeller Nut	SUS316L	1
25	Set Screw	SUS316L	3
26	M6*8L Set Screw	SUS316L	2
27	Plug R1/2"	SUS316L	1

No.	Parts Name	Material	Qty.
29	M8*20L Hexagon Socket Screw	SUS316L	4
30	M8 Spring Washer	SUS316L	4
31	M12*35L Hexagon Screw	SUS316L	8
32	M12 Washer	SUS316L	8
33	Gasket Ø219*Ø205*1.5t	PTFE	1
34	Adapter	FC25	1
37	Outer Magnet Coupling	SS400+RareEarth	1
38	Baseplate	SS400	1
41	Plug R3/8"	PP	1
42	Nameplate	SUS304	1
43	M16*45L Hexagon Screw	SUS316	4
44	M16 Washer	SUS316	4
45	M12*35L Hexagon Screw	SUS316	4
46	M12 Washer	SUS316	8
47	M12*40L Hexagon Screw	SUS316L	4
48	M12*20L Ring	SS400	1

10. Torque for bolts and nuts

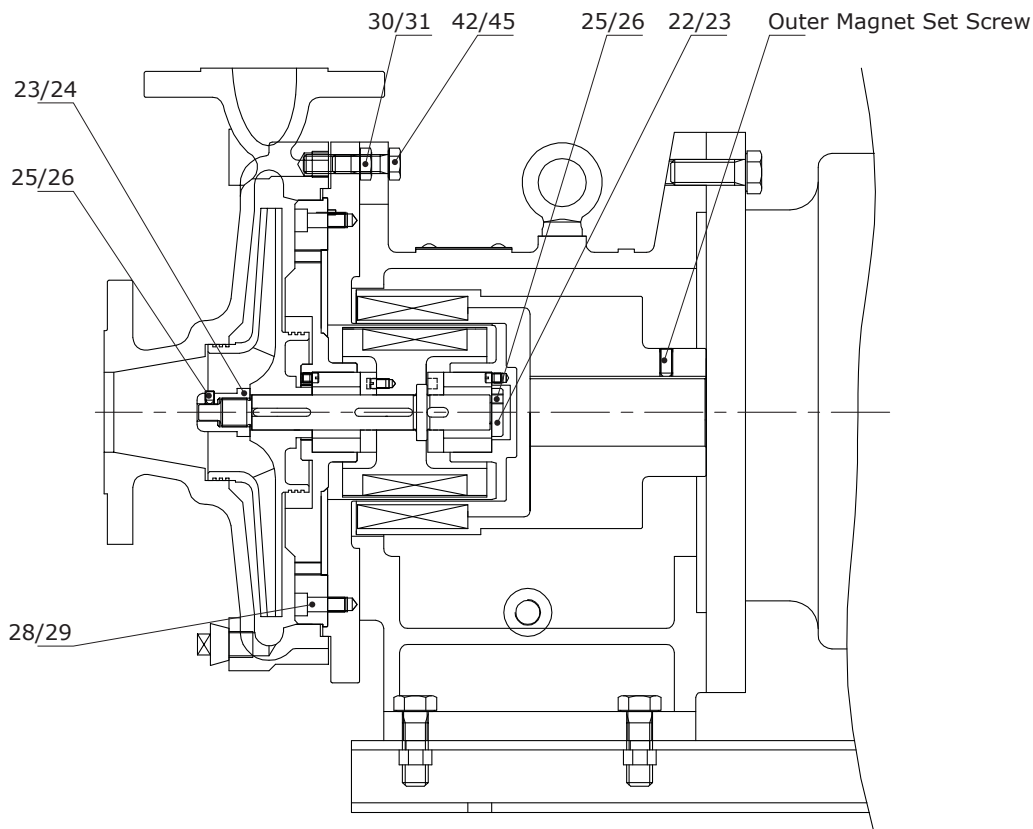

No.	Motor Frame (132)	23	25	22	25	28	30	42	---
	Motor Frame (160)	24	26	23	26	29	31	45	---
Parts Name	Impeller Nut (Impeller)	Set Screw (Impeller)	Shaft Bolt (Shaft)	Set Screw (Shaft Bolt)	Hexagon Socket Screw (Casing Cover)	Hexagon Screw (Front Casing)	Hexagon Screw (Adapter)	Set Screw (Outer Magnet)	
Model									
PL-40x25-160									
PL-40x25-200									
PL-40x25-200LF									
PL-50x25-250LF									
PL-50x40-160	M18 98.1 N•m (10 kgf•m)	M6 2.4 N•m (0.24 kgf•m)	M14 45.1 N•m (4.6 kgf•m)	M6 2.4 N•m (0.24 kgf•m)	M8 12.0 N•m (1.22 kgf•m)	M12 42.2 N•m (4.3 kgf•m)	M12 42.2 N•m (4.3 kgf•m)	M8 21 N•m (2.14 kgf•m)	
PL-50x40-200									
PL-50x40-250									
PL-80x50-160									
PL-80x50-200									
PL-100x80-160									

11.Repairs and guarantee

When the problem is happened, please read this instruction manual and try to troubleshoot the problem. If the problem cannot be found or solve and if replacement parts are needed, please call the supplier and provide the following information:

(1) The pump model and manufacturing serial number indicated on the nameplate.

(2) The operating condition.

(3) The situation under which the pump fails.

The warranty period of the pump is based on the purchase date of customer and is under normal use for the one year (if purchase contract has been change of warranty date issue, please follow the purchase contract as standard), except for consumables such as SiC ring and gaskets.

During the warranty period, if the pump failure is due to design or manufacturing reasons, the company is responsible for free maintenance or replace of the pump.