

# AME PUMP RANGE

END SUCTION, HORIZONTAL, **MAGNETIC DRIVE**, CENTRIFUGAL PUMPS



- ∞ CAPACITY <math>< 180M^3 /HR</math>
- ∞ HEAD <math>< 50</math> Metres
- ∞ HIGH TEMPERATURE RESISTANCE
- ∞ HIGH PURITY PFA LINING
- ∞ HEAVY DUTY ISO2858 PROCESS PUMPS
- ∞ HIGH TEMPERATURE RESISTANCE
- ∞ HIGH CHEMICAL RESISTANCE

Part of the  
**MAGNETIC DRIVE**  
Pump Range



## ∞ AME OVERVIEW

The AME range are heavy-duty process pumps designed with a metallic armour and high purity PFA-lining to handle the toughest applications and for transferring high purity aggressive chemicals. Designed to ISO 2858 standards, these magnetic drive pumps are built for reliable and leak-free operation in the most arduous of applications with temperatures <math>< 150^{\circ}C</math> thanks to the patented structural design.

## ∞ ROBUST DESIGN

The biggest concern with heavy duty seal-less pumps made from engineering plastic has been the shaft support system as it must be strong enough to withstand the radial forces during operation. The AME range is designed to balance radial force and reduce the bearing load which also reduces the noise level as a result.

The AME mag drive range feature a patented, integrated 'V' shape front support that is integral to the metal casing which is then PFA lined. This improves the liquid flow to the impeller, increasing operational efficiency, reducing NPSHr and ensuring a long service life. The one piece PFA lining and internal SSiC parts give outstanding chemical resistance to practically all corrosive applications, even at temperatures up to <math>150^{\circ}C</math>.

## ∞ PROVEN RELIABILITY

All Crest Mag Drive pumps come with a 2 year warranty as standard with an optional 5 year extended warranty for further peace of mind and additional assurance these pumps are built to last in the toughest of applications.



**2 YEARS  
WARRANTY**



**ATEX ZONE 1/2  
AVAILABLE**



**PFA  
LINED**



**HIGH TEMPERATURE  
RESISTANCE**



**ISO 2858, 5199,  
15783**



**CORROSION  
RESISTANCE**



**LOW PUMP LIFE  
CYCLE COSTS**



**HIGH EFFICIENCY  
DESIGN**

# AME PUMP RANGE

END SUCTION, HORIZONTAL, **MAGNETIC DRIVE**, CENTRIFUGAL PUMPS

## AME BENEFITS

### A. Rigid Shaft Support

Traditionally, plastic chemical pumps either have a single sided shaft support or only use plastic for a double-ended shaft support. The problem with this is that under high temperature or pressure, the shaft support weakens resulting in shaft deflection and therefore vibrations leading increased wear and reduced service life.

The AME range features a patented integral V shape front support that is part of the metal casing armour and then PFA lined. The rear of the shaft is supported in the PFA lined containment shell and reinforced by a metal support ring and high-strength carbon fibre composite cover.

This superior design means a longer design life resulting in far less downtime and increased productivity.

### B. Vacuum Resistant Lining

The PFA lining is formed directly onto the metal armour and designed to ensure the PFA material remains adhered to the armour even under low absolute pressure.

### C. Load Balanced Volute

The casing volute is designed to have an evenly distributed hydraulic pressure, providing a balanced radial loading on the impeller.

### D/E. One piece, metal embedded impeller

Traditionally, an ETFE or PFA mag drive pump will be fitted with a separate impeller and inner magnet. In applications of high pressure or temperature, the impeller can deform resulting in damages and reduced performance.

The AME pump range is built whereby the impeller and magnet capsule are formed as one piece which eliminates the possibility of the impeller loosening. For further operational stability and rigidity, a metallic structure is embedded from the magnet capsule to the impeller blade further increasing the pump's operational life.

### F. Simple Construction

The stationary shaft design allows for a very simple construction which makes maintenance and repairs very simple.

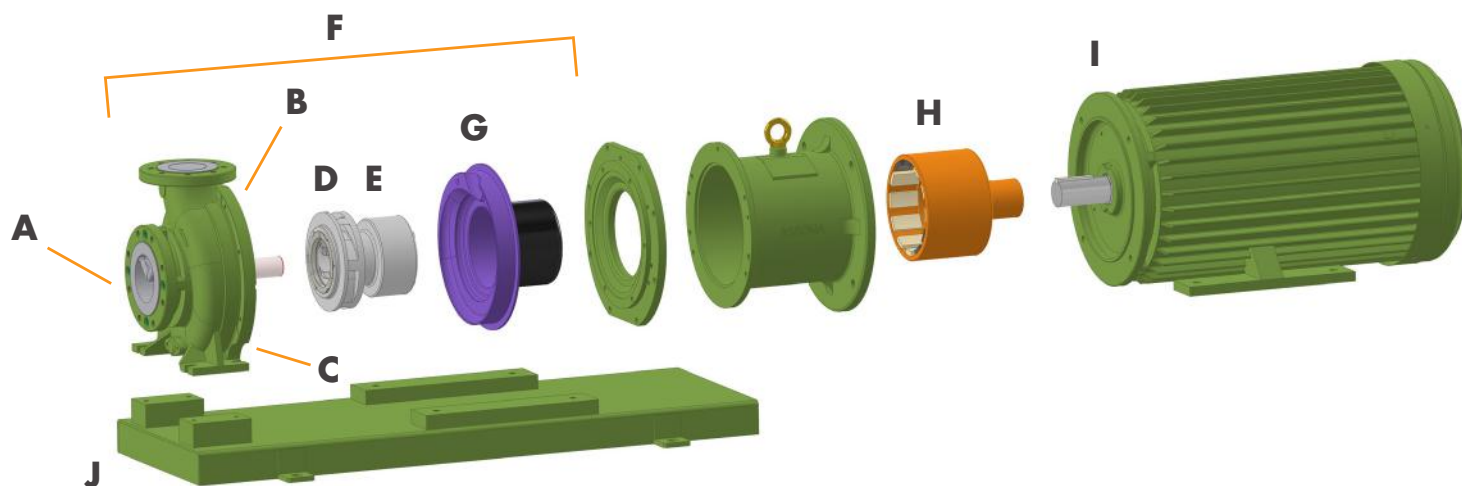

### G. Reinforced Containment Shell

The plastic containment shell is reinforced with a carbon fiber composite cover. There is no eddy current loss, so no additional heating of the pumped chemical.

### H. High Strength Magnetic Coupling

Inner magnets are constructed from Samarium Cobalt (SmCo) in order to withstand high operating temperatures without experiencing demagnetization. High strength neodymium (NdFeB) is then used for the drive magnet to provide high torque transmission.

### I. Back Pull-Out

Simple and quick maintenance access without the need to remove the pump casing from the piping.

### J. ISO Standardised

Designed to ISO 2858, ISO 5199, ISO 15783, and EN 809 standards.

# AME PUMP RANGE

END SUCTION, HORIZONTAL, **MAGNETIC DRIVE**, CENTRIFUGAL PUMPS

## PUMP RANGE CURVES

Pump curves for the magnetic drive AME-BP, AME-BT, AME-CP, AME-CT, AME-EP, AME-FP and AME-HT

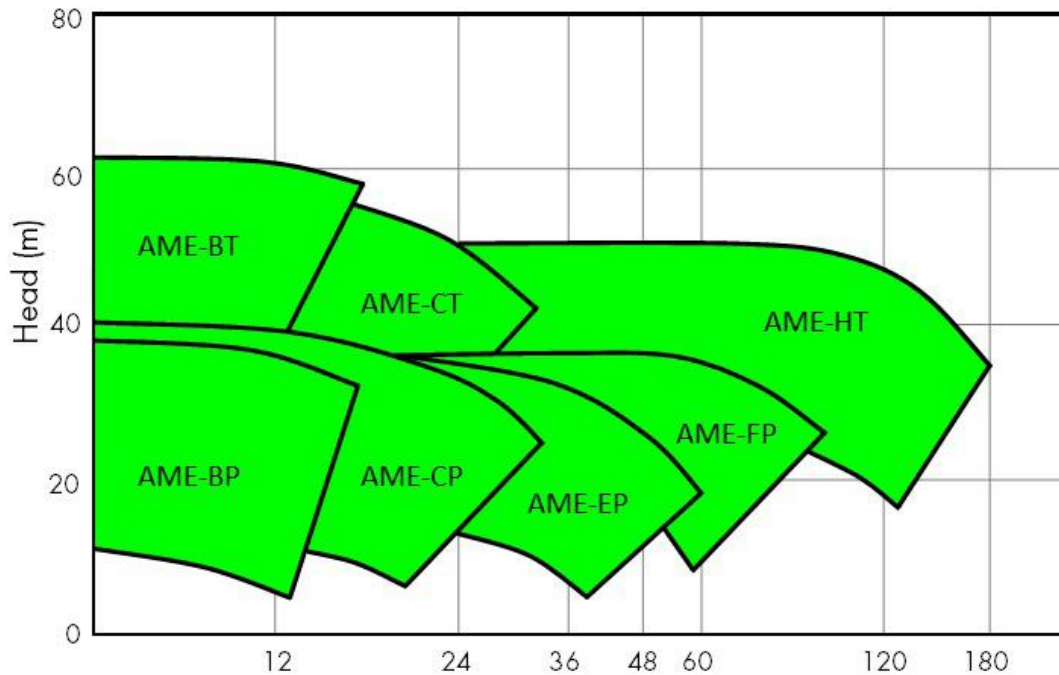

## TECHNICAL SPECIFICATION

MODEL	INLET X OUT-LET BORE SIZE (mm)	IMPELLER DIAMETER (mm)	RATED CAPACITY (m <sup>3</sup> /hr)	RATED HEAD (m)	SHAFT POWER (kW)	MOTOR OUTPUT (kW)
AME-BP	40 x 25	168	10.8	34.4	1.8	1.5, 2.2 or 4
AME-BT	40 x 25	210	10.8	61.1	4.3	5.5 or 7.5
AME-CP	50 x 32	168	20	35.6	3.3	1.5, 2.2 or 4
AME-CT	50 x 32	210	24	49.5	6	5.5 or 7.5
AME-EP	65 x 50	165	30	32	4.8	5.5 or 7.5
AME-FP	80 x 65	170	50	32	6.5	5.5, 7.5 or 11
AME-HT	100 x 80	200	150	43.3	24.1	11, 15, 18.5, 22 or 30

## AME BENEFITS

The AME range features a patented integral V shape from support that is part of the FCD450 metal casing which is then PFA lined. The one piece PFA lining gives outstanding chemical and corrosion resistance to practically all corrosive liquids and applications even with temperatures exceeding 150°C.

All models in the AME range are built to ISO2858 dimensions and the baseplate is built to ISO3661. Flanged connections are available as ANSI or DIN as standard. This makes replacing old, outdated and inefficient pumps extremely simple and cost effective for your business.

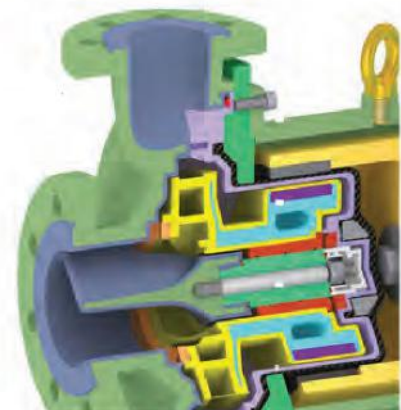

# AME PUMP RANGE

END SUCTION, HORIZONTAL, **MAGNETIC DRIVE**, CENTRIFUGAL PUMPS

## ∞ RANGE DIMENSIONS

For specific 3D CAD drawings or specific pump dimensions, please contact us at [info@crestpumps.co.uk](mailto:info@crestpumps.co.uk) or telephone +44 (0)1425 627700.

### NOTE:

1. The total length and weight of the pump will differ depending on the brand of the motor.
2. All dimensions are in mm.
3. Assembly tolerances are +/- 3mm.

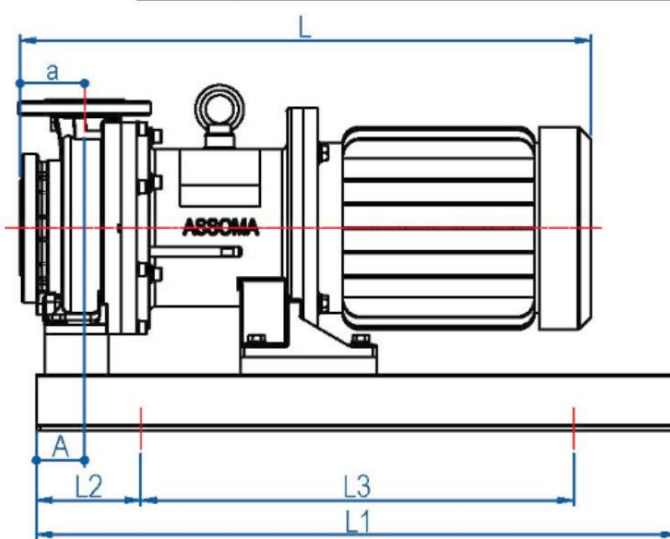
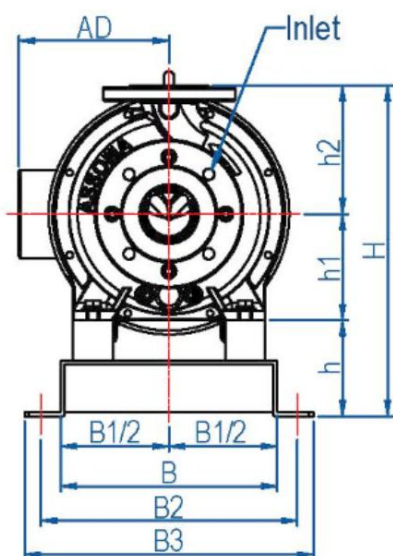
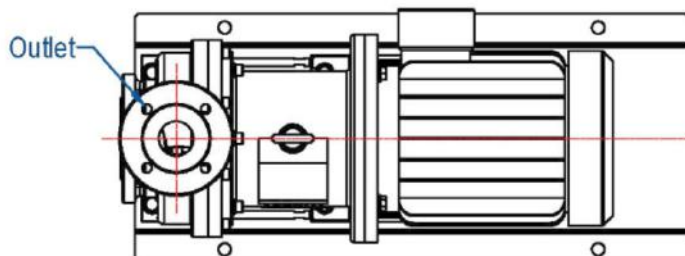

PLEASE ALLOW FOR MANUFACTURING TOLERANCES OF UP TO +/- 3MM

MODEL	A	a	AD*	B1	B2	B3	d	H	h	h1	h2	L*	L1**	L2	L3	Inlet ***	Outlet ***	Motor Output kW	Frame Size						
AME-BP	60	80	143	270	360	320	18	412	120	132	160	551	800 (550)	130	540 (290)	40A	25A	1.5	96S/L						
			166									576						2.2	112M						
												649						3.7							
AME-BT	60	80	168	270	360	320	18	460	120	160	180	680	800	130	540	40A	25A	5.5 7.5	132S						
AME-CP	60	80	143	270	360	320	18	412	120	132	160	551	800 (550)	130	540 (290)	50A	32A (40A)	1.5	90S/L						
			166									576						2.2	112M						
												649						3.7							
AME-CT	60	80	168	270	360	320	18	460	120	160	180	680	800	130	540	50A	32A (40A)	5.5 7.5	132S						
AME-EP	60	80	168	270	360	320	18	412	120	132	160	680	800	130	540	65A	32A (40A)	5.5 7.5	132S						
AME-FP	60	100	225	360	360	320	18	460	120	160	180	790	800 900	130	660 740 840	80A	65A	5.5	132S						
			263									390						390	350	20	915	900	150	7.5	160M
																					960			11	160L
																							15	18.5	
AME-HT	75	100	263	340	450	400	23	525	120	180	225	947	1000 1120 1250	170	540 600	100A	80A	11	160M						
			305									380						490	440		991	190	15	160L	
			324									430						540	490		1011	205	18.5	180M	
																					1179		22	180L	
																							30	200L	

# AME PUMP RANGE



END SUCTION, HORIZONTAL, **MAGNETIC DRIVE**, CENTRIFUGAL PUMPS

## CASE STUDY - SEA WATER

**“AME pumps have been supplied to the world’s leading chemical manufacturing companies including BASF and DOW, along with some more unusual applications”**

One of the more unusual applications for this range was for pumping seawater through large condensers on an air conditioning plant on one of the world’s largest private sailing yachts.

The engineers were experiencing reliability issues with a mechanically sealed pump and so wanted to move to a more reliable, mag drive option. When in the middle of an ocean, you can understand why reliability is paramount!

Eos is a three-masted Bermuda rigged schooner. The 300ft long ship is one of the largest private sailing yachts in the world and boasts three 200ft high masts. It was built by Lurssen in Germany at their Bremen shipyard in 2006.



## CREST MAGNETIC DRIVE PUMPS - UTILISED BY



## APPLICATIONS

**CHEMICAL**  
Chemical applications include chemical transfer, dosing, re-circulation, filtration, fume scrubbing and tanker off-loading.

**PETROCHEMICAL**  
Previous petrochemical installations include high temperature, high pressure, highly viscous applications as well as chemical injection, re-circulation, off-loading and solid handling.

**WATER TREATMENT**  
Providing reliable process pumps to the UK’s largest wastewater treatment providers, for chemical transfer, desalination, reverse osmosis, water treatment and tanker unloading.

**PHARMACEUTICAL**  
Pharmaceutical companies have relied on Crest Pumps to provide pumps for ATEX requirements, chemical injection, CIP pumping, solid handling, high viscous medias and highly toxic applications.

**BIOFUELS**  
Fully ATEX certified process pumps for transfer of liquids in explosive atmospheres, solids handling, tanker unloading, recirculation and transfer.

**ENERGY GENERATION**  
Pumps supplied for various energy generation applications, including wind turbine, solar, and Vanadium redox flow batteries.

**MARINE**  
Centrifugal pumps supplied for various below deck applications including ballast water treatment, electrolysis, desalination and sea water cooling systems.