

AVF PUMP RANGE

VARIABLE FREQUENCY **CANNED MOTOR PUMPS**

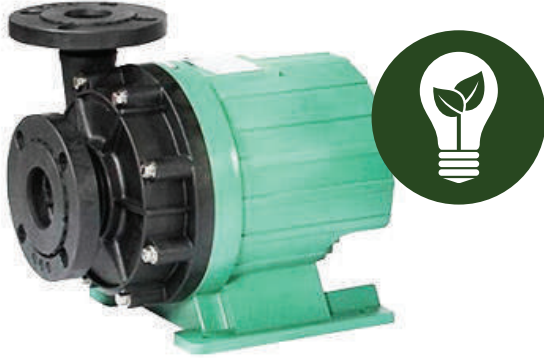

- ∞ CAPACITY <math>< 84 \text{ m}^3/\text{hr}</math>
- ∞ HEAD <math>< 35 \text{ Metres}</math>
- ∞ POLYPROPYLENE / ETFE CONSTRUCTION
- ∞ CANNED MOTOR, SEAL-LESS
- ∞ TOTAL CORROSION RESISTANCE
- ∞ REDUCED LIFE CYCLE COST
- ∞ LOW NOISE

Part of the **MAGNETIC DRIVE** Pump Range



∞ AVF OVERVIEW

IF YOU ARE CURRENTLY USING A PUMP WITH AN INVERTER FOR VARYING DUTY POINTS, THE AVF WILL UNDOUBTEDLY REDUCE YOUR RUNNING COSTS.

A bold statement, but the new AVF canned Magnetic drive pump leads the way in high efficiency, low energy pumping. The issue is that induction motors are bulky and low in efficiency from their very design. When an Inverter is added to control the pump, the overall system efficiency is further reduced, diminishing the effectiveness of energy consumption.

Canned motor pumps integrate the design of the electric motor and magnetic drive pumps into one. The stator of the motor directly drives the inner magnet of the pump, eliminating the motor rotor and the drive magnet. Because the AVF range uses a permanent magnet rotor and there is no induced current compared to an induction motor, efficiency is increased by up to 20% and power consumption reduced by 50% or more.

When specifying any pump, the user must look at the overall life cycle cost (LCC) in order to make an informed decision. The AVF range reduces the variable costs of pump ownership (energy usage, repair costs, downtime) as these account for over 80% of the LCC.

Through in depth hydraulic, rotor, electrical and magnetic analysis, AVF motors exceed current IE3 efficiency limits. As of 2018, the 1.1kW and 2.2kW models exceed IE4 standards whereas 4kW and 7.5kW models exceed future IE5 efficiency limits.



**2 YEARS
WARRANTY**



**ATEX ZONE
1/2 CERTIFIED**



**ENERGY
SAVING**



**CORROSION
RESISTANCE**



**50% ENERGY
SAVING**



IP66

AVF PUMP RANGE

VARIABLE FREQUENCY **CANNED MOTOR PUMPS**

PUMP RANGE CURVES

Pump curves for the polypropylene AVF canned Magnetic Drive pump ranges 221, 441, 553/543, 555/545 and 655.

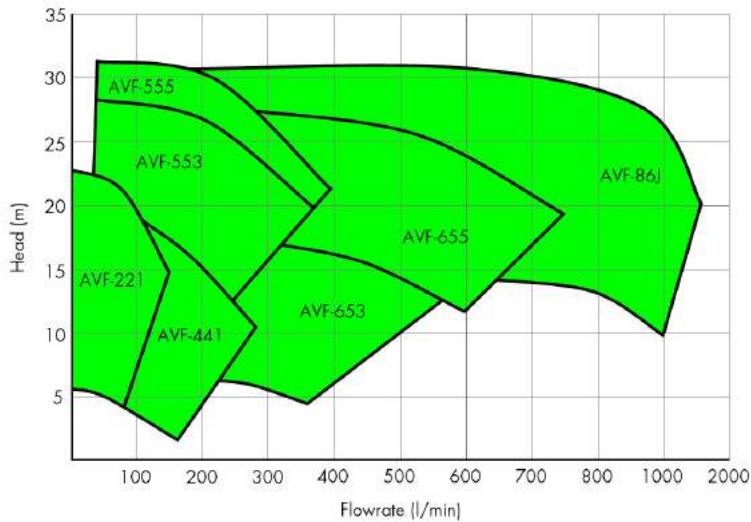

INFORMATION

Everything's Reduced!

Because the AVF range is a fan less design, both heat and noise are significantly reduced compared to traditional mag drive pumps.

And because of the canned motor principle, they are smaller and lighter weight, taking up less floor space and easier to manouvre for maintenance.

TECHNICAL SPECIFICATION

		AVF-221	AVF-441	AVF-553	AVF-653	AVF-555	AVF-655	AVF-86J
Capacity Range (L/min)		10 - 80	20 - 300	40 - 450	60 - 600	60 - 500	80 - 750	80 - 1400
Head Range (m)		6 - 23	5 - 21	8 - 31	4 - 22	8 - 31	7 - 28	10 - 31
Max Motor Output (kW)		1.1	1.1	2.2	2.2	4	4	7.5
Rated Current	220V	3.8	3.8	7.3	7.3	13	13	27
	380V	2.2	2.2	4.2	4.2	7.5	7.5	15.6
Speed Range (rpm)		1500 - 3000						
Protection Grade		IP66						



AVF PUMP RANGE

VARIABLE FREQUENCY CANNED MOTOR PUMPS

∞ RANGE DIMENSIONS

For specific 3D CAD drawings or specific pump dimensions, please contact us at info@crestpumps.co.uk or telephone +44 (0)1425 627700.

NOTE:

1. The total length and weight of the pump will differ depending on the brand of the motor.
2. All dimensions are in mm.
3. Assembly tolerances are +/- 3mm.

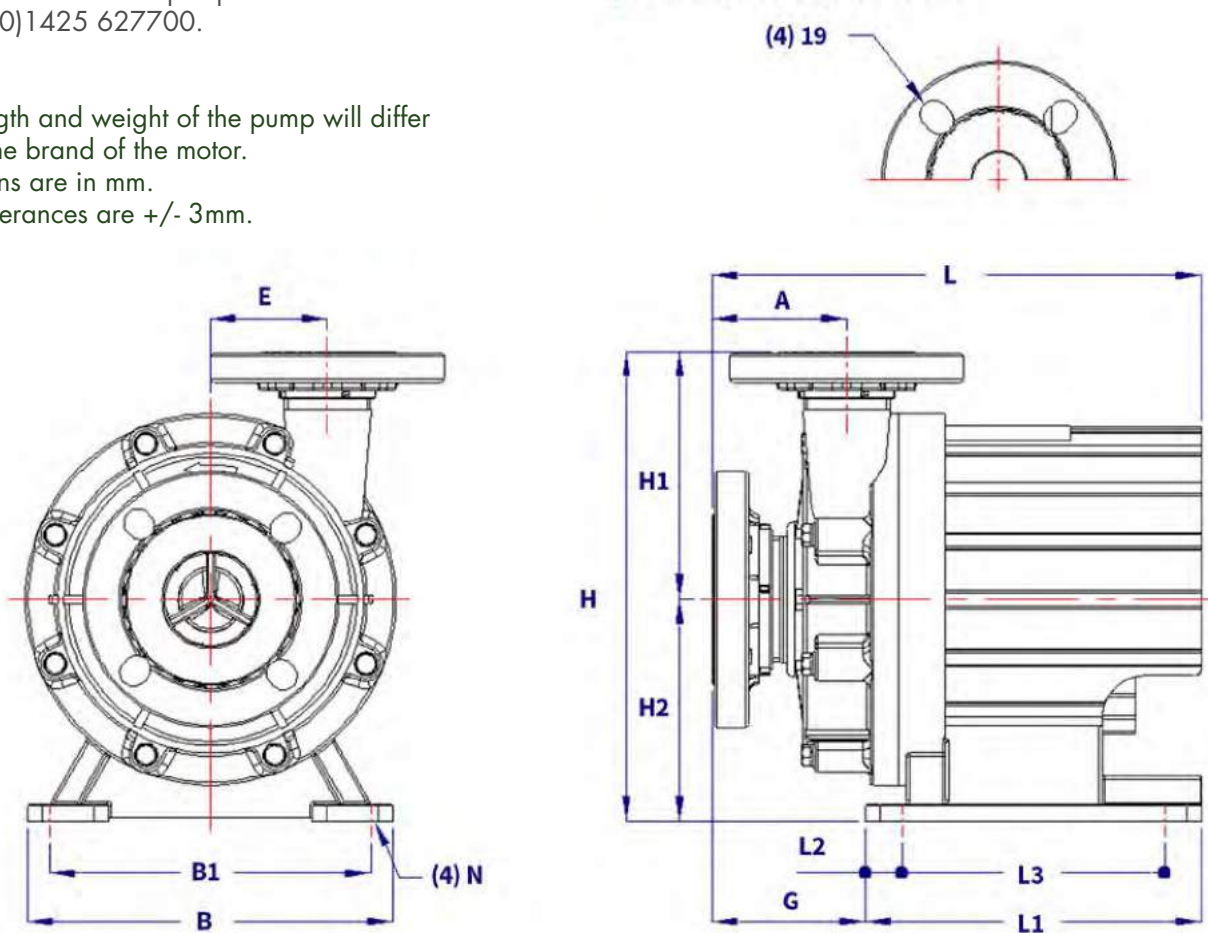

MODEL	DIMENSIONS (mm)													BORE (mm)		FLANGE	
	A	B	B1	E	G	H	H1	H2	L	L1	L2	L3	N	INLET	OUT-LET	INLET	OUT-LET
AVF 221	90	225	196	65	95	255	140	115	270	180	25	130	12	21	21	25A	25A
AVF 441	106	225	196	72	111	258	143	115	286	180	25	130	12	21	21	40A	40A
AVF 543	91	250	210	80	99	313	161	152	329	230	25	180	14	50	40	50A	40A
AVF 545						312	160										50A
AVF 553						312	160										50A
AVF 555						312	160										50A
AVF 655	92	394	350	0*	105	322	170	192	335	270	20	230	12	65	50	65A	65A
AVF 86J	148				408	216	404		270					20	230	12	

AVF PUMP RANGE

VARIABLE FREQUENCY CANNED MOTOR PUMPS

EXPLODED VIEW

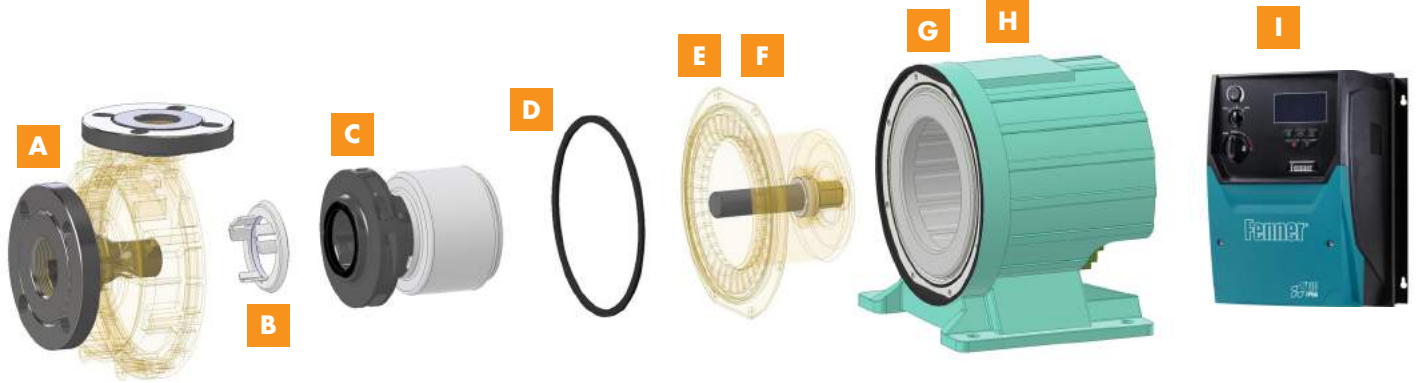

- A Maintenance-Free Pump Casing** - The flanges are socket welded to the pump casing eliminating the need for O-rings, thus requiring zero maintenance. The flanges are also adjustable in order to easily align with mating flanges for a secure and leak-free seal.
- B Patented Buffer System** - In order to increase the pumps life, the unique buffer system design absorbs any shock generated during abnormal pump operation such as cavitation.
- C High-Efficiency Impeller** - The closed impeller is precision designed to streamline flow dynamics, minimising hydraulic loss and maximising pump efficiency.
- D Increased MTBS** - The strengthened gasket seal is specially designed for extended leak-free service. This allows for a much longer Mean Time Between Servicing.
- E Rigid Shaft Support** - To improve operational reliability and an increased service life, the stationary shaft is supported on both ends. It is tightly fitted in the containment shell and supported by the strong metallic frame of the motor.
- F Plastic Containment Shell** - The AVF is constructed using a seal-less canned design, with the motor's stator providing the direct drive to the pump's rotor. This eliminates the need for a coupling interface, thus greatly reducing the axial dimension and weight of the pumps.
- G High-Efficiency Motor** - As a permanent magnet synchronous motor, these currently exceed IE4 and future IE5 efficiency standards. Being fan-less and smaller, they generate little heat or noise, whilst taking up less space.
- H Corrosion Resistant Outer Casing** - Constructed from Engineering plastics, the entire pump is IP66 rated, providing full protection for the motor against accidental chemical drips/corrosive environments. This also acts as a secondary containment shell in the event of catastrophic pump failure.
- I Inverter Controlled** - Running the pump with an inverter means you only use the energy required for the process, and when running at lower speeds, it will extend the service life of wear parts.

HIGHER EFFICIENCY - REDUCED COST

Laboratory tests carried out show the greater efficiency of the AVF pump with synchronised motor, compared to the traditional induction motor.

----- AVF 555 at 2850 rpm ——— Magnetic drive seal-less pump with induction motor

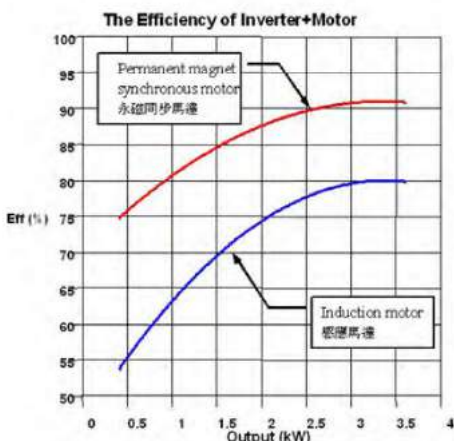

TESTING

In our tests, we compared the AVF-555 pump at 2850 RPM with a magnetic drive seal-less pump of similar specifications coupled with an induction motor.

The result was a 5% higher overall efficiency with the AVF pump, saving 0.2 to 3 kW of power under the same hydraulic power output.

But the real cost saving comes when the pump is used for a duty below the rated speed. Because an AC motor with inverter becomes very inefficient at lower speeds, the input power greatly increases when compared to the AVF shaft power.

AVF PUMP RANGE

VARIABLE FREQUENCY **CANNED MOTOR PUMPS**

PARTS LIST AND MATERIAL CONSTRUCTION

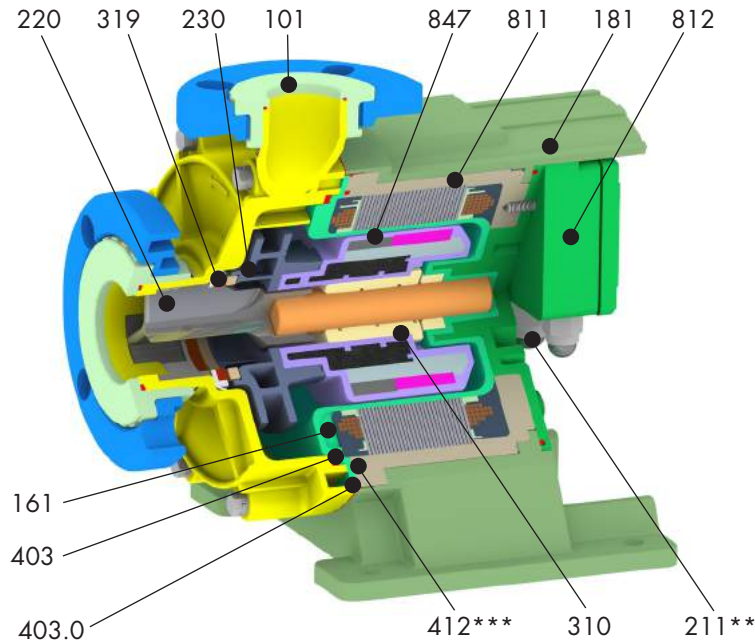

MATERIAL CODE	PART	AVAILABLE MATERIAL	Q'TY
101	PUMP CASING	PP + GF / ETFE + CF	1
161	THRUST RING	995 Al ₂ O ₃ / SSiC	1
161	CONTAINMENT SHELL	PP + GF / ETFE + CF	1
181	BRACKET	PP + GF	1
211**	SHAFT	995 Al ₂ O ₃ / SSiC	1
220	FRONT SUPPORT, SHAFT	ETFE + CF	1
230	FRONT WEARING	CARBON / SSiC / PTFE WITH FILLER	1
230	IMPELLER	PP + GF / ETFE + CF	1
310	BEARING	995 Al O / SSiC / CARBON / PTFE WITH FILLER	1
319	FRONT THRUST RING	995 Al ₂ O ₃ / SSiC	1
319	FRONT BUFFER	ETFE	1
403	GASKET	EPDM / VITON	1
403.0	PACKING	EPDM / VITON	1
725.01	INLET FLANGE ADAPTOR	PP+ GF / ETFE + CF	1
725.02	OUTLET FLANGE ADAPTOR	PP+ GF / ETFE + CF	1
811/812	MOTOR HOUSING / REAR FRAME	ALUMINIUM 356	1
847	MAGNET CAPSULE	PP / ETFE, ND-FE-B	1
F21/31	SLIDE BEARING	PP / ETFE, ND-FE-B	1
412***	O RING	EPDM / VITON	1

211** The shaft (211) (1.1 kW) model is removable from the containment shell (161).

412*** Alternative O-ring / Gasket materials are available for critical applications. Please contact us for further information.



AVF PUMP RANGE

VARIABLE FREQUENCY CANNED MOTOR PUMPS

CASE STUDY

A leading PCB manufacturer was asked to carry out an experiment to compare the real life efficiency savings of an existing application where an AMX655 with AC induction motor and inverter was currently used. A power meter was installed and the power absorbed was compared at 3 different duty points. As shown, the greater the variation in duty points required by one single pump, the greater the savings in running costs.

The PCB manufacturer which is a key supplier to Samsung has now begun to transfer all pumps to the AVF range because of the clear demonstration of cost savings that the AVF range can provide. It wasn't only the cost savings that impressed this particular client – the footprint of the AVF pump is smaller and they are also considerably quieter thanks to the fan less design.

DUTY POINT		OPERATING FREQ. (Hz)		POWER CONSUMPTION (kW)		ENERGY SAVING BY AVF
Q (l/min)	H (m)	AMX	AVDF	AMX-655	AVF-655	
320	2	30	95			0.855-0.656 =0.199 kW SAVE 23.2%
485	8	44	136			2.082-1.671 =0.411 kW SAVE 19.7%
540	11	50	156			2.868-2.453 =0.415 kW SAVE 14.5%

CREST MAGNETIC DRIVE PUMPS - UTILISED BY



APPLICATIONS



CHEMICAL

Chemical applications include chemical transfer, dosing, re-circulation, filtration, fume scrubbing and tanker off-loading.



PETROCHEMICAL

Previous petrochemical installations include high temperature, high pressure, highly viscous applications as well as chemical injection, re-circulation, off-loading and solid handling.



WATER TREATMENT

Providing reliable process pumps to the UK's largest wastewater treatment providers, for chemical transfer, desalination, reverse osmosis, water treatment and tanker unloading.



PHARMACEUTICAL

Pharmaceutical companies have relied on Crest Pumps to provide pumps for ATEX requirements, chemical injection, CIP pumping, solid handling, high viscous medias and highly toxic applications.



BIOFUELS

Fully ATEX certified process pumps for transfer of liquids in explosive atmospheres, solids handling, tanker unloading, recirculation and transfer.



ENERGY GENERATION

Pumps supplied for various energy generation applications, including wind turbine, solar, and Vanadium redox flow batteries.



MARINE

Centrifugal pumps supplied for various below deck applications including ballast water treatment, electrolysis, desalination and sea water cooling systems.